

KCM-50-1/51-1

Multi-counter (Maintenance Counters)

The KCM-50 series has 9 counters aggregated into one unit, while the KCM-51 series has 8 counters aggregated into one unit).

These devices can indicate tool replacement for machining centers, NC industrial machinery, and the like as well as maintenance periods for multiple tools.

- Tool management: Replacement notification/warning
- Whetstones for grinding: Maintenance notification
- Quantity management: Total counters/preset counters
- Time management: Integration timers

KCM-50 series

KCM-50/KCM-50-1 KCM-50P/KCM-50P-1

This counter is equipped with 9 units for count input/presetting/independent alarm output (increased count output). The counter produces output when an individual unit reaches set values for equipment halt.



- Open collector output: **KCM-50 (Surface sheet in Japanese)**
KCM-50-1 (Surface sheet in English)
- Voltage output: **KCM-50P (Surface sheet in Japanese)**
KCM-50P-1 (Surface sheet in English)

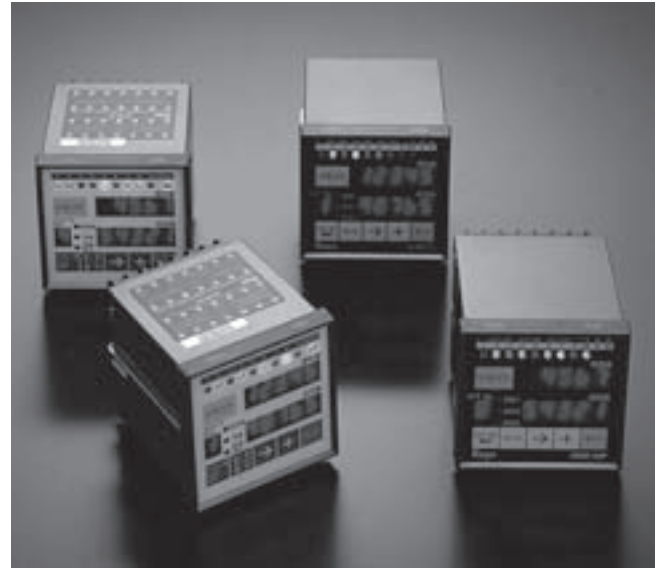

KCM-51 series

KCM-51/KCM-51-1 KCM-51P/KCM-51P-1

This counter is equipped with 8 units for count input/presetting/independent alarm output (increased count output). The counter produces output when an individual unit (timer) reaches set values for equipment halt.



- Open collector output: **KCM-51 (Surface sheet in Japanese)**
KCM-51-1 (Surface sheet in English)
- Voltage output: **KCM-51P (Surface sheet in Japanese)**
KCM-51P-1 (Surface sheet in English)

KCM-50-1/51-1

KCM-50 series

Merits

● **Nine 5-digit preset counters are aggregated into one unit**

● **Battery-less**

Retention of set values and count values is maintenance-free thanks to use of EEPROM.

● **Independent alarm (preset) output from 9 circuits**

● **Color-differentiated display pre-alarm (green)-alarm (orange)-equipment halt (red)**

The pre-alarm is provided to indicate when alarm values are being approached.

● **Equipment halt output**

Over-values are set with respect to set alarm values for individual counters. Equipment halt (displayed in red) is output whenever a counter reaches over-values.

● **These 9 preset counters can also be used as a total counter**

The counters can be preset (alarm setting) independently to output preset values (displayed in orange) when counts are input.

● **Oil-resistant front operation panel**

● **Small (DIN 72 x 72mm)**

The counter's depth is 82 mm, which makes it thin enough for a control panel.

Application example: Tool maintenance for multi-axial industrial machinery

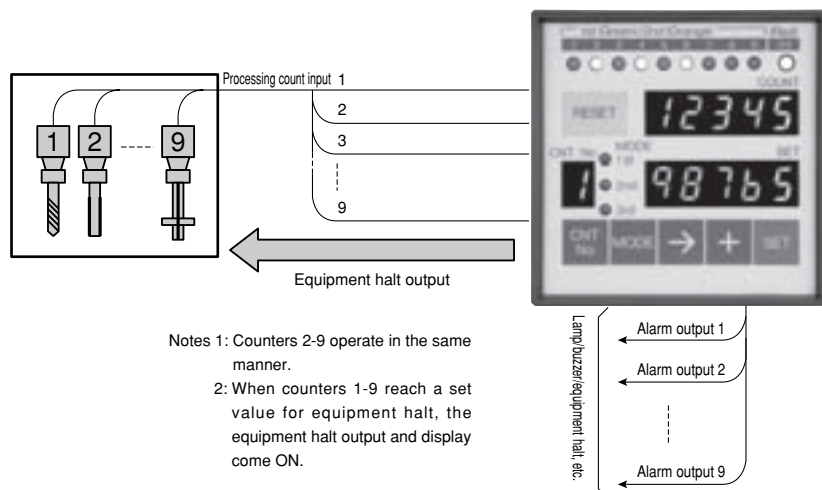

Basic operations Timing chart (KCM-50/50-1)

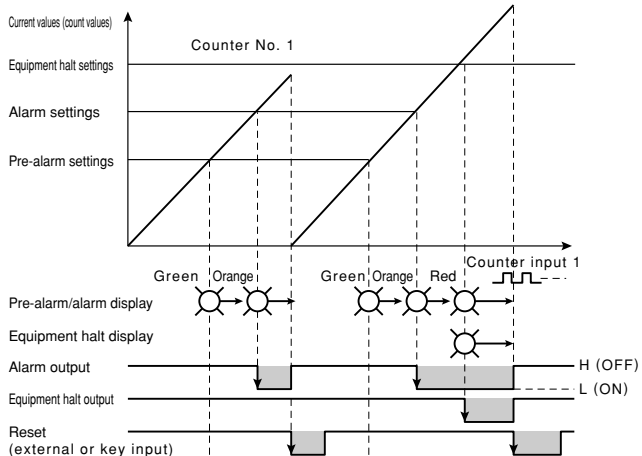

KCM-51 series

Merits

● **Eight 5-digit preset counters (timers) are aggregated into one unit**

● **Battery-less**

Retention of set values and count values is maintenance-free thanks to use of EEPROM.

● **Independent alarm (preset) output from 8 circuits**

● **Color-differentiated display for counters (timers) upon reaching set values**

Setting 1 (green)-Setting 2 (orange)- Setting 3 (red)

● **OR output**

Output is produced by any of the counters (timers) upon reaching Setting 1 values or Setting 3 values.

● **These 8 preset counters can also be used as a total counter or integrated timer**

Use of counter and timer functions can be mixed.

● **Any counter /timer can be reset with an external signal.**

● **Oil-resistant front operations panel**

● **Small (DIN 72 x 72)**

The counter's depth is 82 mm, which makes it thin enough for a control panel.

Basic operations Timing chart (KCM-51-1/51-1)

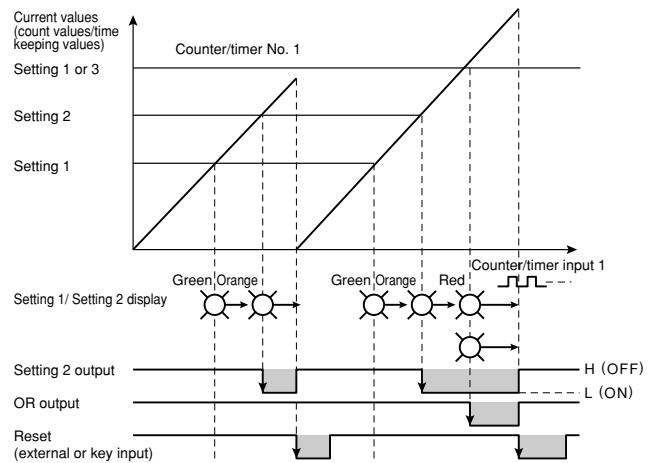

Application example: Tool maintenance for multi-axial industrial machinery

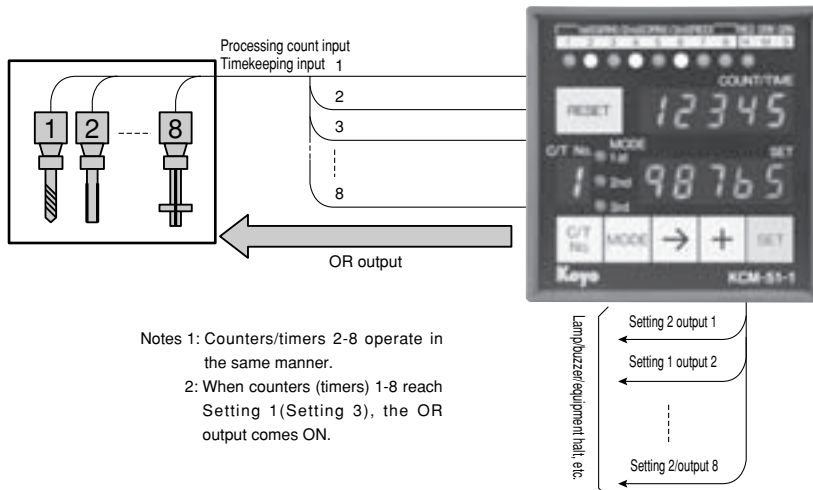

Notes 1: Counters/timers 2-8 operate in the same manner.
 2: When counters (timers) 1-8 reach Setting 1(Setting 3), the OR output comes ON.

KCM-50-1

Front Panel Layout and Description

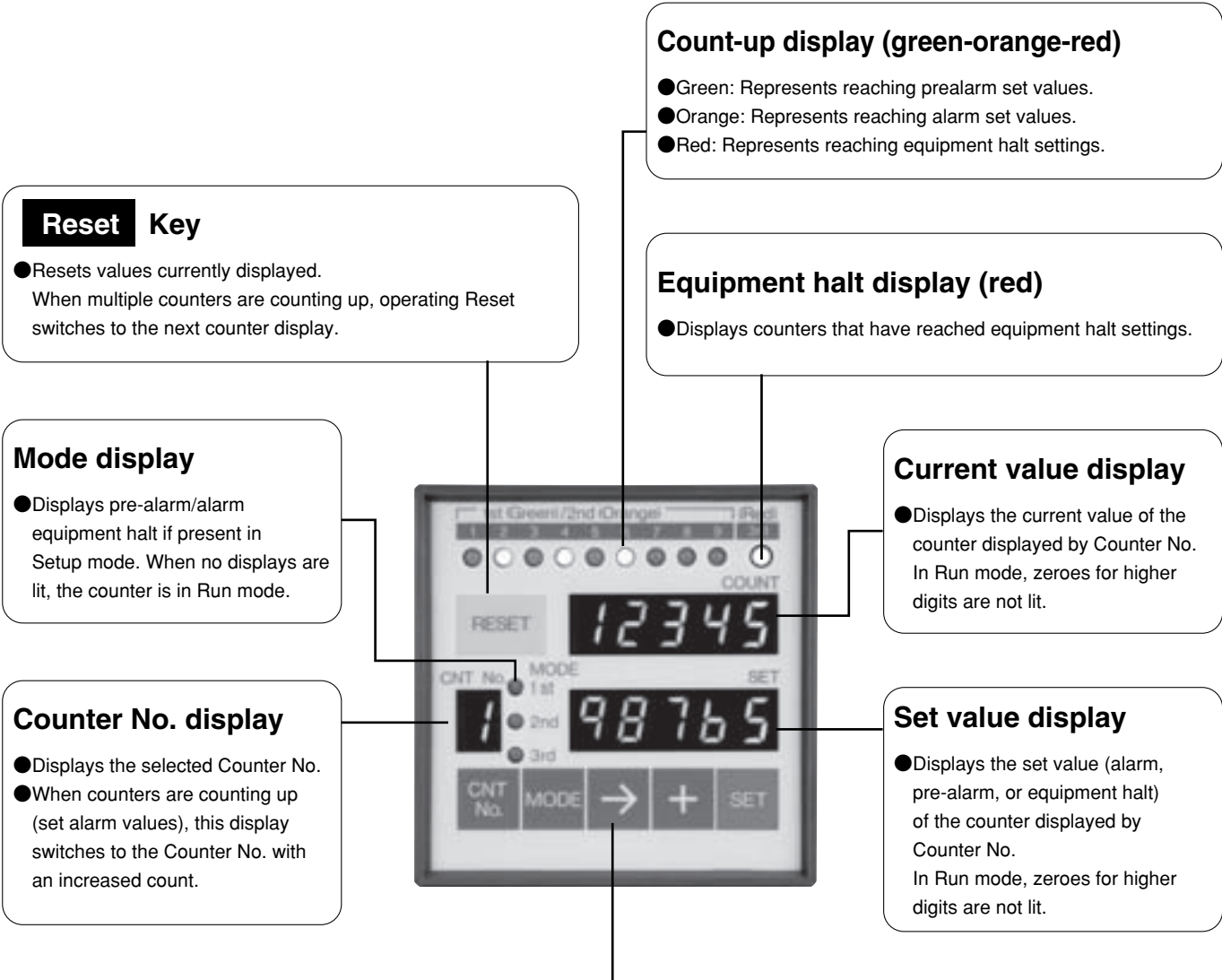

CNT No. Key

- Switches the counter's Current value display and Set value display.

→ 1 → 2 → 3 ----- 8 → 9

- In Run mode, unused counters are not displayed.
- Continue to push this key for more than 1 second and the display will automatically advance.

MODE Key

- Switches between Run mode and Setting modes.

Setting modes

→ Run → Alarm → Pre-alarm → Equipment halt

When no key input continues for longer than 1 minute, the display automatically switches to Run mode.

→ Key (Digit Selection Key)

- Used for selection of digits during set value input.

→ 5th digit → 4th digit ----- 1st digit

- The selected digit flickers.
- Continue to push this key for more than 1 second and the display will automatically advance.

+ Key (Value Advancement Key)

- The number of the digit selected is advanced with this key.

→ 0 → 1 → 2 ----- 8 → 9

- Continue to push this key for more than 1 second and the display will automatically advance.

SET Key

- This key sets values as set in memory in Setting mode. Once set, a portion of the Set value display will blink 3 times, which represents input.

Input and Output/Specifications

●Block Diagram KCM-50

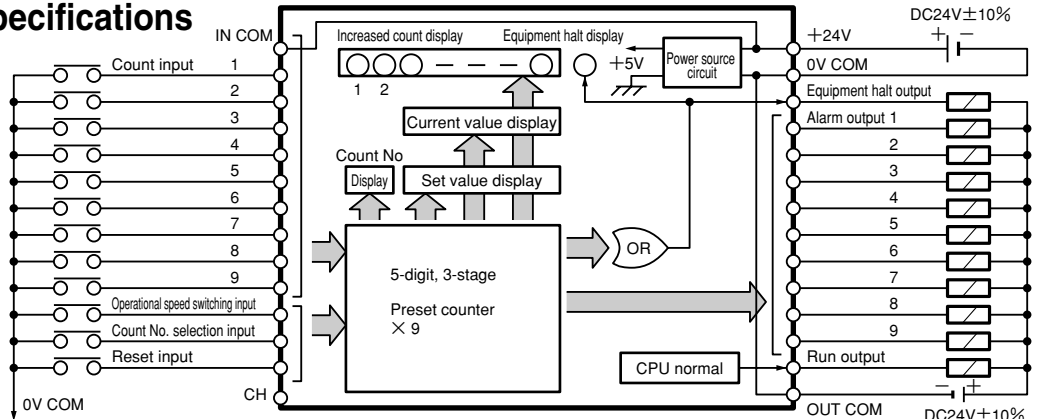

KCM-50P

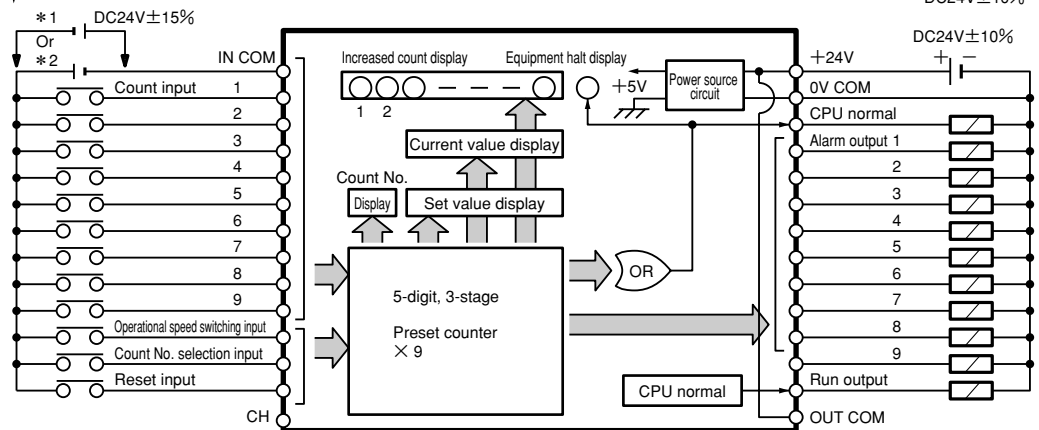

* 1 Positive logic
* 2 Negative logic

Terminal number	I/O	Explanation of functions	Specifications
5, 6, 7, 12, 13, 14, 19, 20, 21	Count input 1~9	Regardless of Run mode/Setting mode, the current values of the counter are added (+1). Current values proceed from H→L, L→H, and L→H (positive logic).	Operational speed 30/500Hz KCM-50 Input voltage ON: 0-3 V OFF: more than 16 V
18	Operational speed switching input	OFF : 30Hz ON : 500Hz	Switching with source ON edge Input resistance: 3.3 kΩ
26	Count No. selection input	Counter selection input $\rightarrow 1 \rightarrow 2 \rightarrow 3 \rightarrow 4 \rightarrow 5 \rightarrow 6 \rightarrow 7 \rightarrow 8 \rightarrow 9 \rightarrow$ Counter No. advances with H→L and L→H (positive logic). In Run mode, unused counters are not selected.	Ondelay: 30ms Offdelay: 30ms KCM-50P Input voltage (Positive logic) ON: 0-6 V OFF: Input open (Negative logic) ON: 16-27.6 V OFF: 0-6 V Input resistance: 2.2 kΩ
25	Reset input	Current values of the counter specified by Counter No. are reset. When input for Counter No. selection and reset are input together within approx. a 5-second interval, all counters are reset.	Ondelay: 0.1s Offdelay: 0.1s
1, 2, 3, 8, 9, 10, 15, 16, 17	Alarm output 1~9	Output when set alarm values are reached with independent output for counter Nos. 1-9.	Duration of input response: 30ms (30Hz) 10ms (500Hz)
4	Equipment halt output	Output when equipment halt settings are reached with output for any counter from Nos. 1-9.	
11	Run output	ON for CPU normal/OFF for CPU abnormal	Response duration ON : After power supply less than 1.5 s OFF: After abnormality sensing less than 10 ms
—	Count No. display	Displays the Counter No. selected via the Counter No. selection key or external counter no. selection input. Switches to the Counter No. (in order of preference) with an increased count when counters are counting up. Order of preference: Equipment halt > alarm > pre-alarm	

KCM-50

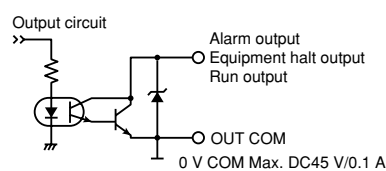
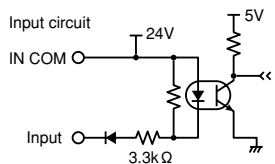

Notes 1: IN COM and 24 V are connected internally to the counter.

2: OUT COM and 0 V COM are connected internally to the counter.

KCM-50P

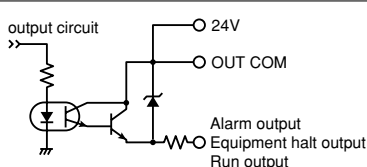
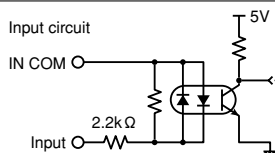

Note: OUT COM and 24 V are connected internally to the counter.

KCM-51-1

Front Panel Layout and Description

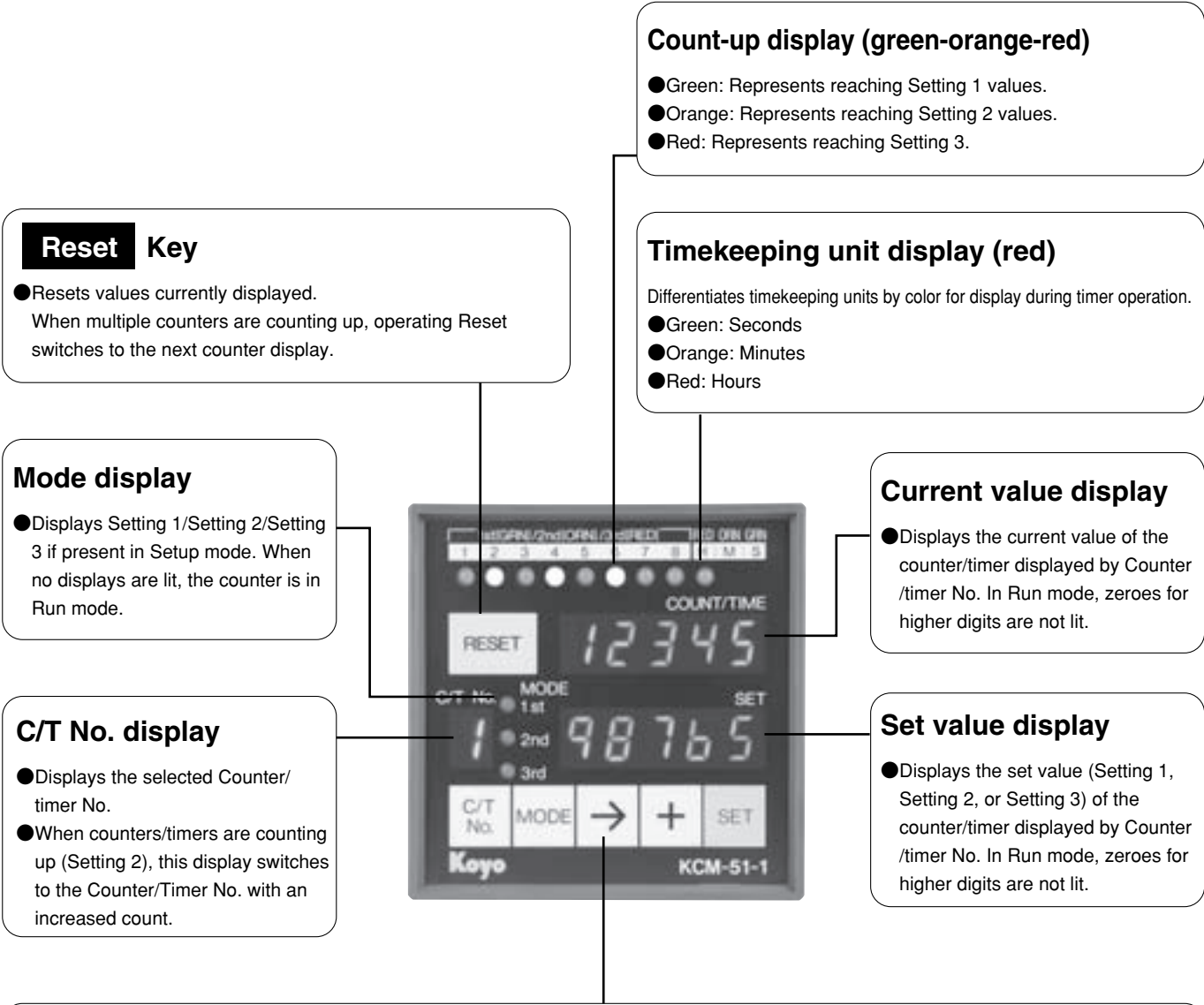

C/T No. Key

- Switches the counter's Current value display and Set value display.

→ 1 → 2 → 3 8

- In Run mode, unused counters/timers are not displayed.
- Continue to push this key for more than 1 second and the display will automatically advance.

MODE Key

- Switches between Run mode and Setting modes.

→ Run → Setting 1 → Setting 2 → Setting 3

When no key input continues for longer than 1 minute, the display automatically switches to Run mode.

→ Key (Digit Selection Key)

- Used for selection of digits during set value input.

→ 5th digit → 4th digit 1st digit

- The selected digit blinks.
- Continue to push this key for more than 1 second and the display will automatically advance.

+ Key (Value Advancement Key)

- The number of the digit selected is advanced with this key.

→ 0 → 1 → 2 8

- Continue to push this key for more than 1 second and the display will automatically advance.

SET Key

- This key sets values as set in memory in Setting mode. Once set, a portion of the Set value display will blink 3 times, which represents input.

Input and Output Functions/ Specifications

●Block Diagram KCM-51-1

- *1 Positive logic input
- *2 Negative logic input

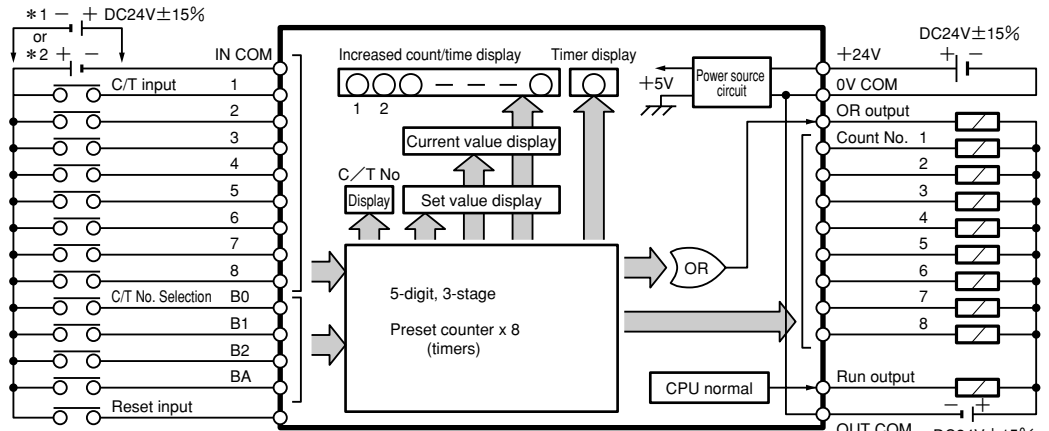

KCM-51P-1

- *3 Positive logic input
- *4 Negative logic input

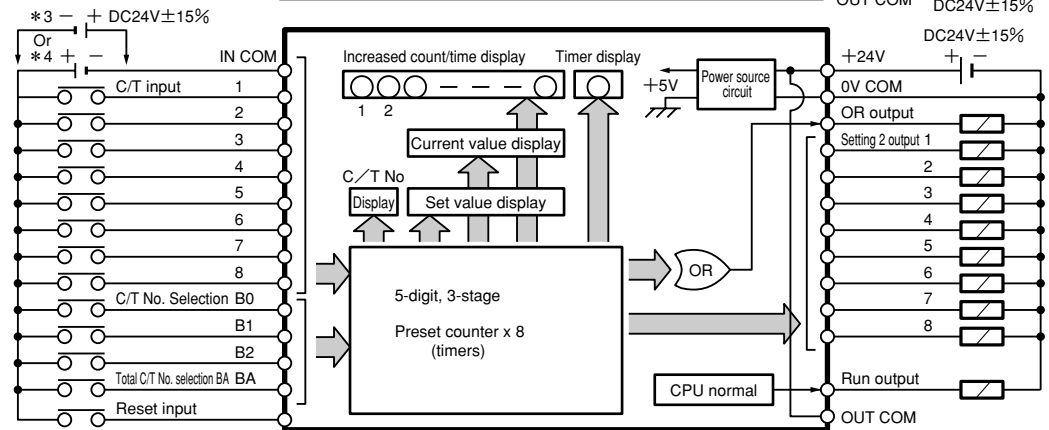

Terminal number	I/O	Explanation of functions	Specifications
5 6 7 12 13 14 19 20	C/T input 1~8	Regardless of Run mode/Setting mode, the count (timekeeping) of the counter (timer) is performed. ●When used as a counter, current values proceed from OFF→ON ●When used as a timer, timing starts OFF→ON. Timekeeping is continuous when ON. Timing is halted with ON→OFF.	Operational speed 30 cps/500 cps Min. pulse amplitude 16.6 ms/1 ms Timekeeping range Hours 1-99999 hrs Minutes 1-99999 mins Seconds 1-99999 s
21, 26, 27	C/T No. Selection input	Specifies 3 inputs (B0, B1, and B2) for the counter/timer No. that is to be reset.	Input voltage (Negative logic) ON: 0-6 V OFF: Input open (Positive logic) ON: 16-27.6 V OFF: 0-6 V Input resistance: 2.2 kΩ
18	C/T No. Selection input	Input is ON when during reset input for all timers and counters to be selected.	
25	Reset	Current values of the selected Counter/timer No. become 0.	
1, 2, 3, 8, 9, 10, 15, 16	Setting 2 output 1~8	Output when Setting 2 values are reached with output for any counter/timer from Nos. 1-8.	Duration of input response: 30 ms (30-Hz timer) 10 ms(500 Hz)
4	OR output	Output when Setting 1 (Setting 3) values are reached with output for any counter/timer from Nos. 1-8	
11	Run output	ON for CPU normal/OFF for CPU abnormal.	Response duration ON: After power supply less than 1.5 s OFF: After abnormality sensing less than 10 ms
—	Counter/timer No. display	Displays the Counter/timer No. selected via the Counter/timer No. selection key or external C/T No. selection input.	

●Default settings: Pressing the Mode key and + key at the same time has the counter enter Default Setting Mode, and default setting of the following data is performed. 1)Counter/timer selection 2)Setting of operational speed/timekeeping units 3)Selection of Reset key disable or enable 4)Set value selection with respect to OR output (Setting 1 or Setting 3)

KCM-51-1/51P-1: Input circuit

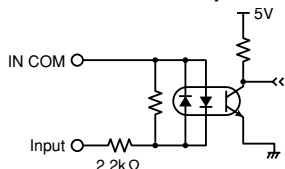

KCM-51-1: Output circuit

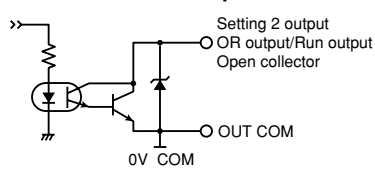

KCM-51P-1: Output circuit

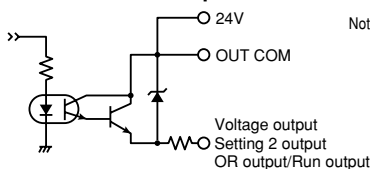

Notes 1: Input common 0 V: Positive logic
24 V: Negative logic

2: Output common
KCM-51-1: 0 V and internally short-circuited
KCM-51P-1: 24 V and internally short-circuited

KCM-50-1/51-1

Electronic Counters

General Specifications (Common to KCM-50-1/51-1 Series)

Item	Specification
Source voltage	DC 24 V ± 15% (20.4-27.6 V) KCM-50-1: DC 24 V ± 10% (21.6-26.4 V)
Power consumption	5W
Ambient temperature	-10 ~ +55 °C
Storage temperature	-20 ~ +70 °C (with no freezing)
Ambient humidity/storage humidity	45 ~ 85%RH (with no dewing)
Insulation resistance	more than 100 MΩ DC500 V 1 minute between power source and input terminals
Withstand voltage	AC500V 50/60 Hz 1 minute (uncharged metallic portion exposed to charged portion and external portion)
Noise resistance	Between power source terminals: ±1 kV (pulse amplitude 1 μs rise 1 ns) Between input terminals: ±500 kV (pulse amplitude 1 μs rise 1 ns)
Vibration resistance	No malfunction: displacement amplitude 0.5 mm 10-55 Hz along three axes Durability: displacement amplitude 0.75 mm 10-55 Hz along three axes
Impact resistance	98m/s ² along three axes
Case packing	Munsell N-4 (dark gray) ABS material
Weight	350g

Model numbers

Model number
KCM-50
KCM-50-1
KCM-50P
KCM-50P-1
KCM-51
KCM-51-1
KCM-51P
KCM-51P-1

(Accessories)
Metal fittings for installation

Terminal arrangement (names and functions)

● KCM-50 Series

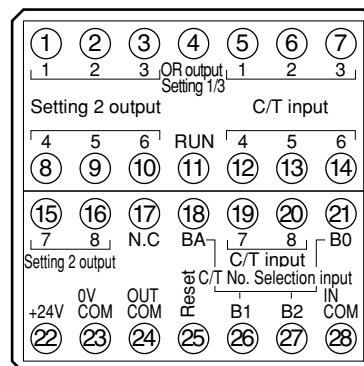
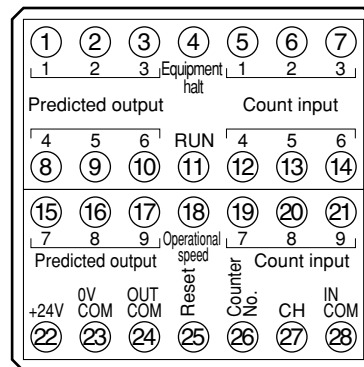





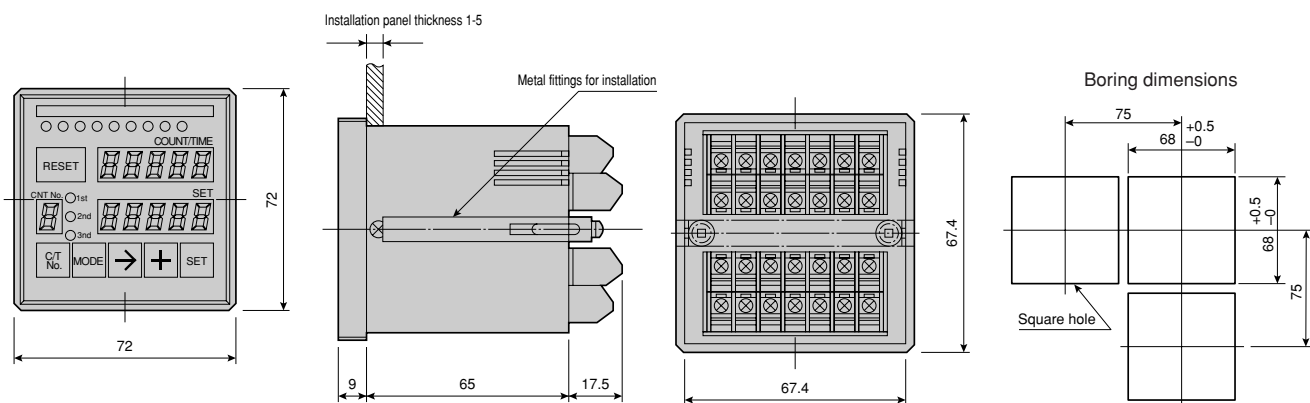

External Dimensions

(in mm)

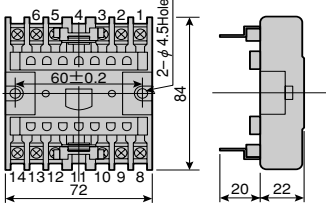

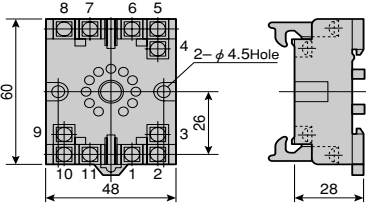
Products Related to Electronic Counters

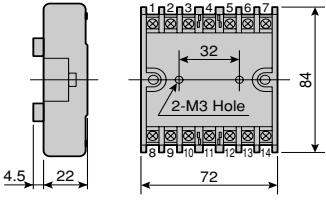
Selecting Socket

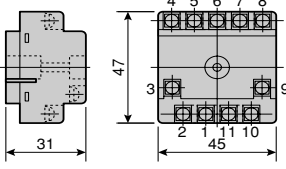
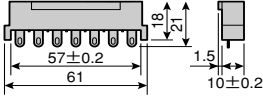
Model number	Appearance	Applicable countents	External dimensions
Sockets for wall surface mounting		KCX KCX-B ※Except KCX-RN	
		TC-4L	
Sockets for flush mounting		KCX KCX-B ※Except KCX-RN	
		TC-4L	
Kit model number	Contents	Applicable counters	External dimensions
Connectors for flush mounting	<ul style="list-style-type: none"> ● Connector ● Support metals ● Screws 	KCX KCX-B ※Except KCX-RN	

Electronic Counters

KCV

KCN-A

KCX

KCM

Clock-pulse generator CPG-22

The clock-pulse-generator provides the pulse which you can use for application requiring high-precision timer for a long period.

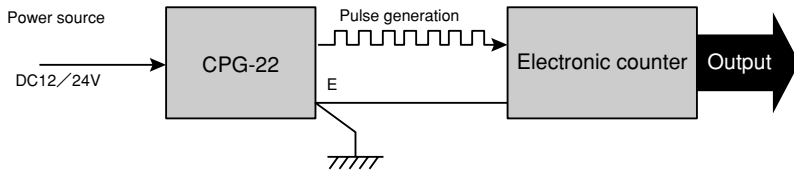

- KCV
- KCN-A
- KCX
- KCM



Specifications

Model number		CPG-22	
Operation		The clock-pulse generator (1 Hz, 10 Hz, and 100 Hz) provides high-precision digital control using a liquid crystal oscillator. It can be used as a high-precision timer in combination with preset counters like KCX series.	
Output	1Hz	Output resistance	Approx. 1.5 Ω (6-9 V)
		Output duration	Approx. 50 ms
	10Hz	Output resistance	Approx. 1.5 Ω (6-9 V)
		Output duration	Approx. 50 ms
	100Hz	Output resistance	Approx. 1.5 Ω (6-9 V)
		Output duration	Approx. 5 ms
Reset input		Input resistance	Approx. 24 Ω
		Response	Less than 1 ms min. pulse amplitude of 5 ms
Power source		DC 12/24 V common (DC 10-30 V)	
Consumption current		30mA	
Ambient temperature		-10~+50°C	
Storage temperature		-20~+70°C (with no freezing)	
Ambient humidity/storage humidity		35~85%RH (with no dewing)	
Accessories		None	

External Dimensions (in mm)

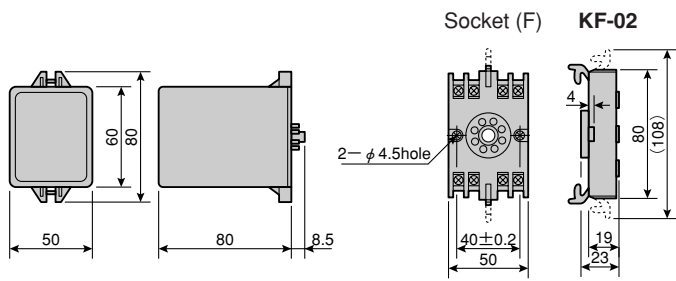

Terminal arrangement

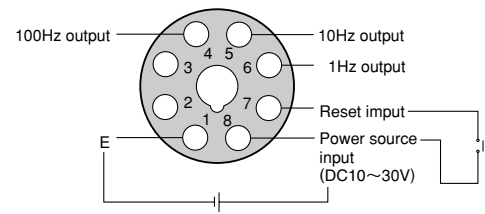

Pulse Generator FG-01

- The pulse generator converts the ON/OFF output of D3-HSC (PLC, Add/sub. counter module) to a pulse train for pulse-motor application.
- The Generator has voltage output to allow high-speed control of DC sensor motors and inverter motors.
- Settings like low speeds, high speeds, timing related to addition and subtraction, and DC voltage output can be set in a broad range via volume on the front panel.
- Count output can be switched between positive and negative logic to allow connection to different types of counters.

Specifications

Item	Specification
Source voltage	AC90~132V / 180~264V 50/60Hz 5VA
High-speed 1	50~3500Hz
High-speed 2	100~9000Hz
Low-speed	15~2000Hz
Timing related to addition and subtraction	30~300ms / 1000Hz
⊕ ⊖ directional input	Negative logic input ON voltage less than 1.5 V OFF voltage more than 8 V ON current 10 mA
Reduced speed output	
High-speed selection input	
Count mode selection input	
CW/CCW pulse output	
CW/CCW count output	Open collector output current 30 mA Pulse amplitude 50 μs (possible to switch between positive and negative logic)
DC output	+9 V 10 mA Max. (can be changed with volume)
Ambient temperature	0~+50°C
Storage temperature	-20~+70°C (with no freezing)
Ambient humidity/storage humidity	35~85%RH(with no dewing)
Accessories	Metal fittings for installation

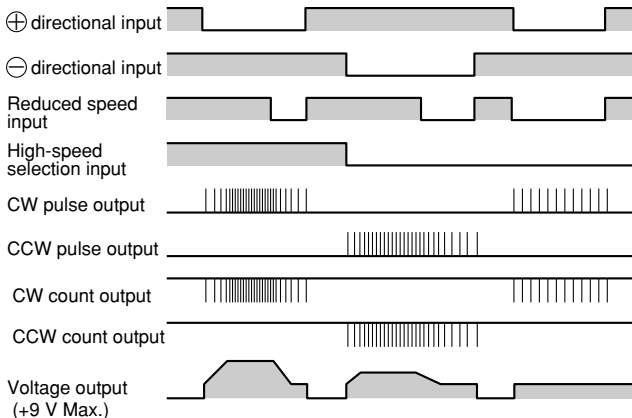

* Voltage output is for positive output only; negative voltage is not output.
 * CW/CCW count output can be switched between positive logic and negative logic.
 * When direction input is entered, switching to high-speed selection input is not possible.



Input circuit

- ⊕ ⊖ directional input
- Reduced speed input
- High-speed selection input
- Count mode selection input

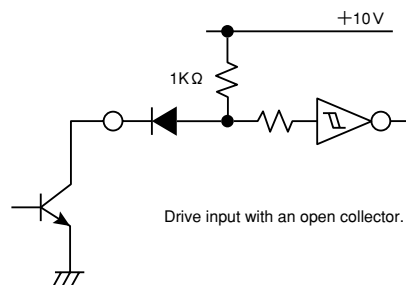

Output circuit

CW/CCW pulse output
(Output for a pulse motor driver)

CW/CCW count output
(Output for a counter)

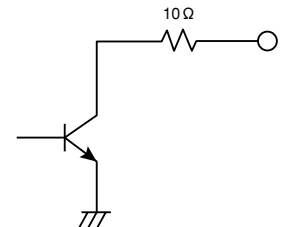
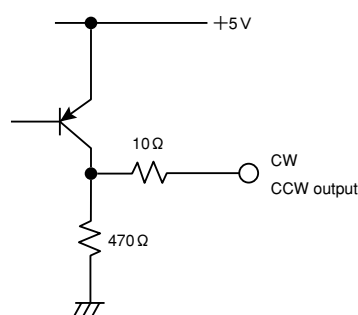

When using positive logic, pull up with resistance.

KCV

KCN-A

KCX

KCM

Terminal arrangement

Terminal number	Explanation		
①	+	Directional input	With this input, CW/CCW pulse outputs and count outputs are produced.
②	-		
③	Reduced speed input		With this input, high-speed changes to low-speed.
④	0V		Input common terminal
⑤	Count mode selection input		Allows switching of positive logic of count output. H: negative logic/L: positive logic
⑥	High-speed selection input		Allows selection of high speed 1 and high speed 2. H: high speed 1/L: high speed 2
⑦	Voltage output		Voltage output corresponding to the pulse frequency.
⑧	CW	Pulse output	Output to a pulse motor driver.
⑨	CCW		
⑩	CW	Count output	Output to a counter for pulse setting.
⑪	CCW		
⑫	AC180~264V	AC source input	
⑬	AC90~132V		
⑭	AC0V		

※The FG-01's external dimensions and exclusive socket are the same as those of the KCX Series counters.
Refer to page B-72.