

KT-V Series

Digital Timers

A large display that is easy to read has been provided in a small DIN48 size.

The large red LED is bright with a character height for display of 12 mm, which allows it to be seen easily from a distance and at an angle. In addition, set values use a green LED to differentiate from timekeeping values. Setting of set values with individual setting keys has the feel of digital switches. Basic function settings are made with digital switches; detailed settings are selected with digit keys, so operation is easy.



Merits

● Tamper proof

Key protection can be set for individual keys to prevent a malfunction or tampering.

● Battery-less memory retention

EEPROM is used to retain values in memory, so there is no need for battery maintenance.

● Removable terminals

Maintenance has been reduced via terminals that can be removed. After wiring, the terminal cover provides a safe surface for worry-free use.

● Power source for a large-capacity sensor

You can source the power for sensor from the built-in P/S 24VDC, 60mA.

● Free power supply for the AC type

The operating AC voltage is wide as 85VAC~264VAC.

● Various types of time ranges

The device covers 10 types of time ranges with times of 0.001 s to 9999 hours.

● Various uses with 5 types of operating modes

Settings can be made for ondelay, offdelay, one-shot, integration, and flicker.

● Display of Elapsed time/Remaining time

The time display can be selected to display elapsed time and remaining time.

● IP65 Protective structure

The front cover panel uses sheet keys, so operation with wet or dirty hands can be done worry-free. A front cover is also provided as an option to enhance the protective structure.

● Designed in compliance with CE and UL

List of Models

Model Number	Number of digits	Source Voltage	Sensor Source Voltage DC24 V 60 mA
KT-V4S	4	AC	●
KT-V4S-C		DC	

(Accessories) Installation Frame

Model number system

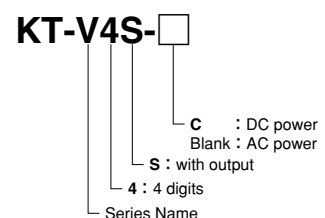

General Specifications

Item	Specification	
	AC power	DC power
Source voltage	AC100~240 V	DC12~24 V
Permitted power fluctuation	AC85~264 V	DC10~26.4 V
Power consumption	Approx. 11 VA	Approx. 4 W
Sensor power	DC24 V (20-28 V) 60 mA (less than 10%p-p ripple noise)	—————
Memory Backup upon Power Failure	EEPROM Writing Up to 100,000 times Memory Duration 10 years	
Ambient temperature	-10~50°C	
Storage temperature	-20~70°C (with no freezing)	
Ambient humidity	35~85%RH (with no dewing)	
Withstand voltage	AC 2kV 1 minute AC 2kV for one minute (for AC input, 0 V, and relay interconnection) (for the DC type, 0 V and relay interconnection only)	
Vibration resistance	Durability	Displacement amplitude 0.5 mm 10~55 Hz along three axes
	No malfunction	Displacement amplitude 0.35 mm 10~55 Hz along three axes
Impact resistance	Durability	490 m/s ² along three axes
	No malfunction	98 m/s ² along three axes
Noise resistance	AC power between terminals ± 1.5 kV (pulse width 1 of μ s and rise time 1 of ns)	DC power between terminals ± 1.0 kV (pulse width 1 of μ s and rise time 1 of ns)
Protective structure	IP65 (front panel only)	
Weight	Approx. 150 g	Approx. 110 g
Terminals	Conforming wiring	0.25~1.65 mm ²
	Conforming crimped contact	R1.25-3
	Permitted torque	0.5 Nm

Performance Specifications

Item	Specification
Category	Timer
Operational format	Ondelay, offdelay, one-shot, accumulation, and flicker (with alarm output)
Number of digits	4 digits
Display	Display of timekeeping values: red LED, Character height 12 mm, Set display: green LED, Character height: 7 mm
Time range	0.001 s~9.999 s/0.01 s~99.99 s/0.1 s~999.9 s/1 s~9999 s/1 s~99 min 59 s/1 min~9999 min /1 h~9999 h/1 min~99 h 59 min/0.1 min ~999.9 min/0.1 h~999.9 h
Display	Elapsed time/Remaining time
Timer precision	0.013% or ± 15 ms (using large values)
Input	Input logic: negative logic (no-load input)/ positive logic (voltage input)
	Input resistance: positive logic 15 k Ω Negative logic 3.3 k Ω (AC power)/1.8 k Ω (DC power)
	Input voltage: "L" 0-3 V "H" 7-30 V
Start input response	Less than 15 ms/5 ms/1 ms
External reset	Min. signal amplitude 5 ms
Output	DC output: NPN open collector output / 24 V 100 mA Withstand pressure 35 V Residual voltage less than 1.5 V
	Relay output: 1 transformer relay AC220V 2A (resistance load)
Output duration (flicker)	10-9999 ms variable every 10 ms
Key protection	Setting of arbitrary keys possible
Installation	Exclusively for embedding (terminal block connection)

Output Operation Chart

Ondelay ↑ : Alarm setting SW 1 2
OFF OFF

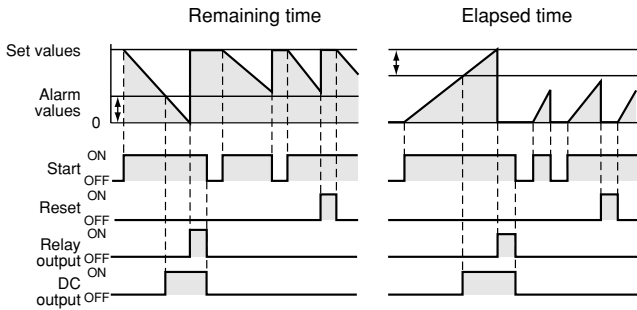

Offdelay SW 1 2
OFF ON

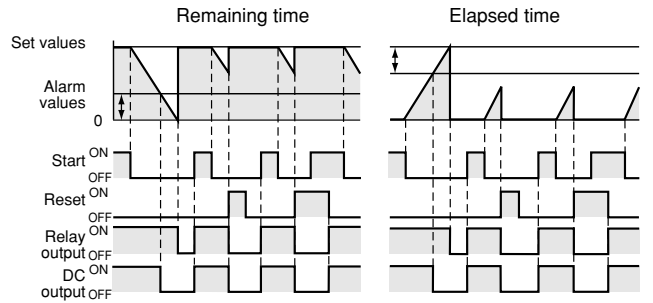

One-shot SW 1 2
ON OFF

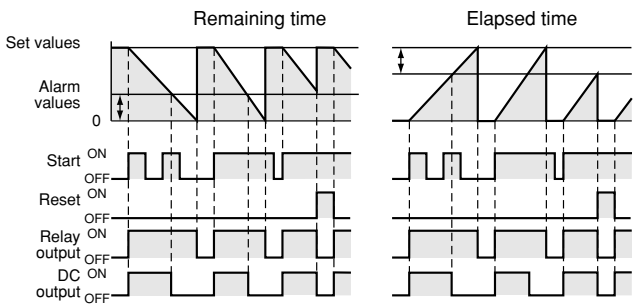

Accumulation SW 1 2
ON ON

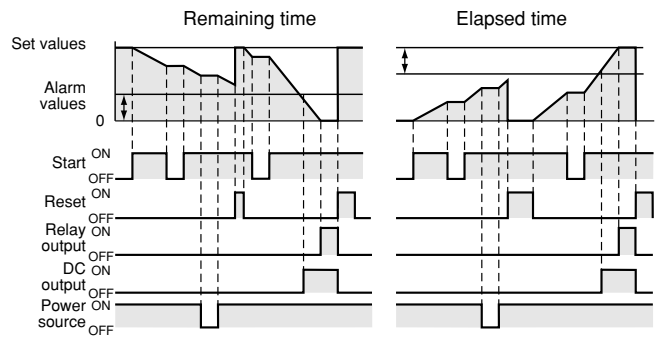

Flicker (in Setup mode)

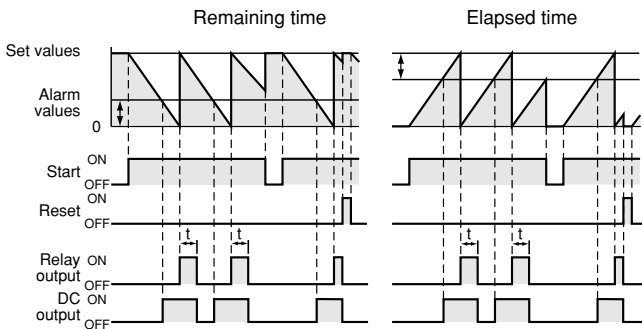

Output time of t is 10~9990 ms variable (100 ms at shipping time)

↑ : Alarm settings When alarm settings are 0, DC output is the same as in output operations for relay output.

- Alarm settings should be smaller values than preset values. Performing alarm setting with values that exceed preset values will result in measurement values of 0; alarm output (DC output) will come ON.

Digital Timers
KT-V

Terminal Wiring Diagrams

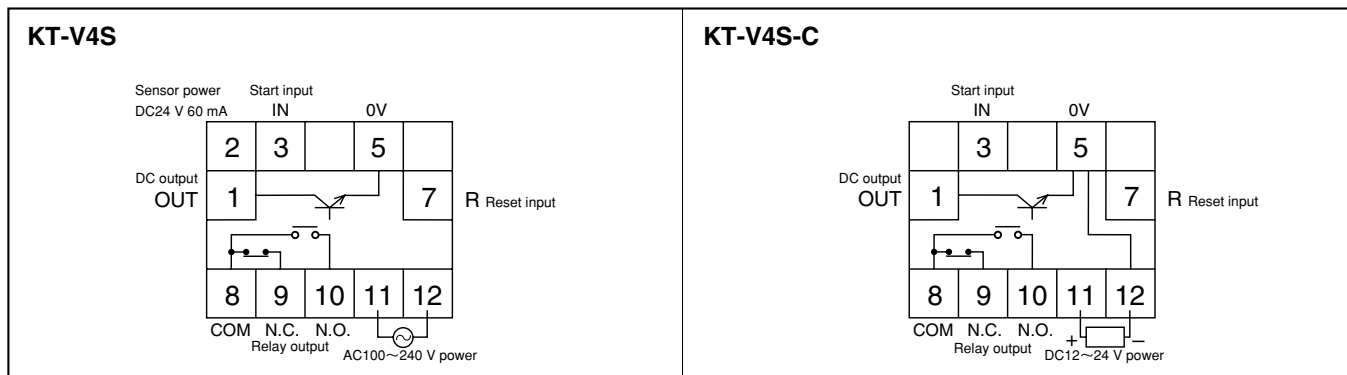

※Alarm output is used in combination with DC output (OUT terminal).

I/O Circuit Diagrams

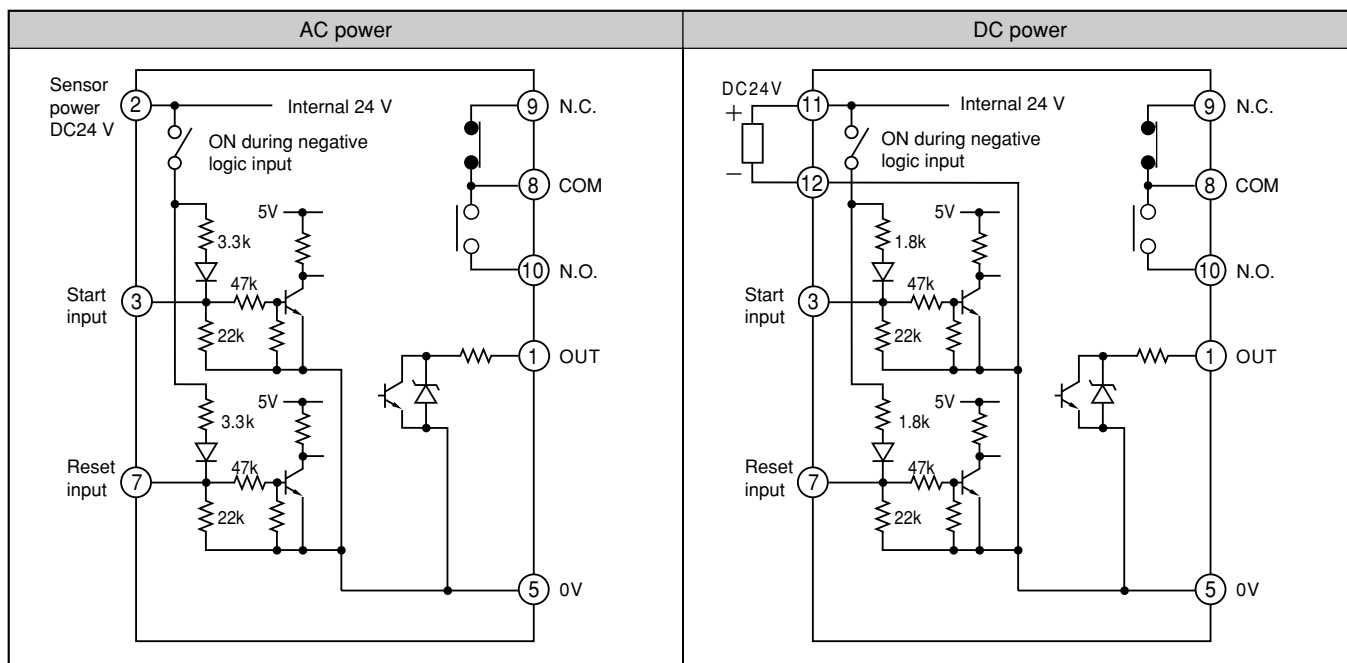

Input Wiring Examples (Start input/Reset input)

Digital Timers

KT-V

<p>Proximity switch with NPN open collector output</p> <p>● Input logic: Negative logic (no-volt input) (nE_L)</p> <p>Recommended proximity switch: APS□-□-N/E</p>		<p>Proximity switch with voltage output or PNP open collector output</p> <p>● Input logic: Negative logic (voltage input) (P_o5)</p> <p>Recommended proximity switch: APS□-□-E2</p>	
<p>DC 2-wire proximity switch</p> <p>● Input logic: Negative logic (no-volt input) (nE_L)</p> <p>Recommended proximity switch: APS□-□-Z</p> <p>※ With the DC type, please supply source voltage above 20 V.</p>	<p>Switch or relay</p> <p>● Input logic: Negative logic (no-volt input) (nE_L)</p> <p>● Start input response: 15 ms</p> <p>● Input current is heavy, so this connection is recommended.</p>	<p>Switch or relay</p> <p>● Input logic: Positive logic (voltage input) (P_o5)</p> <p>● Start input response: 15 ms</p>	

※ There is no DC power source. Use a separate external power source.

Output Wiring Examples

<p>NPN open collector output</p> <p>Relay drive possible</p> <p>Load for specified DC 24 V power source</p>	<p>Relay output</p>
---	---------------------

Front Panel Layout and Description

① Output (red)

- Operating mode
Lit when output is ON.
Blinks when alarm output is ON.

② Key protection (red)

- Operating mode
Blinks when key protection is ON (only when the key is ON).
- Setup Mode
Displays key protection settings.

③ Timekeeping values (red)

- Operating mode
Displays timekeeping values.
- Setup mode
Displays setting parameters.

④ Units

- Operating mode
Displays units for timekeeping values.
H: hours/m: minutes/ s: seconds

⑤ Set values (green)

- Operating mode
Displays set values.
- Setup mode
Displays set items.

⑥ Digit keys

- Operating mode
Allows changes in set values.
※ After changing set values, total key input is ineffective for about one second. Set values then take effect.
- Setup mode
Allows selection of setting parameters.

⑦ RST key

- Operating mode
Allows timekeeping values to be reset (0 for Elapsed time and set values for Remaining time).
- Setup mode
Allows selection of set items.

Time range	Time/Set values	Units
□□□□ s	0~9999	s
□□□□ min	0~9999	m
□□□□ hour	0~9999	h
□□ min □□ s	0:00~99:59	m:s
□□ hour □□ min	0:00~99:59	h:m

Key Operation

1. Changing set values

Press a digit key once to increase the corresponding digit by one:

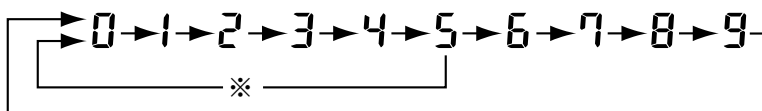

After removing your finder from the key, the settings will be verified after about one second.

※ When the digit of the display is advanced to 60 □□ : ■□
(minutes) (seconds)
(hours) (minutes)

Example: When the current settings are "123"

Press the **[1]** key and the display changes to 124
Press the **[2]** key and the display changes to 134
Press the **[3]** key and the display changes to 234

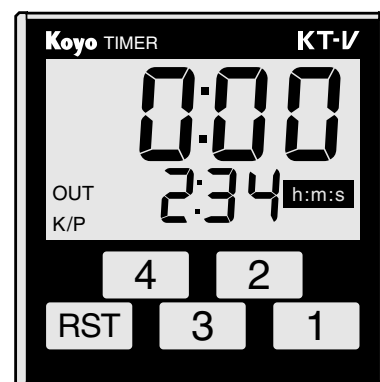

2. Resetting the timekeeping values

Press the **[RST]** key to reset the timekeeping values. The count is reset within 0.1 second after the key is pressed. When the Reset key is pressed in the display mode for remaining time, values become set values. In the display mode for elapsed time, they become 0.

3. Protecting the keys

Turning the Dip switch ON disable the reset and digit keys. If disabled keys are pressed, the LED for the corresponding key will blink. If Key protection is selected to disable keys in Setup mode, Dip switch 6 will come ON. As the factory setup, Key protection in Setup mode is completely disabled, so just turning Dip switch 6 ON will disable all keys.

Configure Dip switches

- Use the dip switch on the top of the counter to configure various parameters and operation mode.
- Configure dip switches with power off. Operation with power up will have no effect.
- When dip switches are re-configured, you must press the Reset key in operating mode to reset the count values.

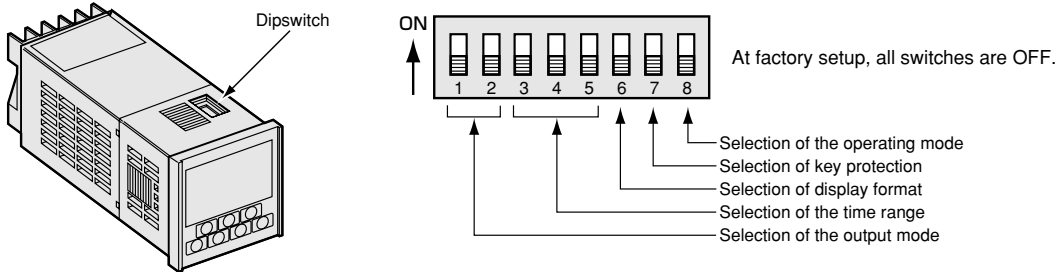

Output mode

The output mode is selected with Dip switches 1 and 2. Blink mode for items not present can be selected in Setup mode.

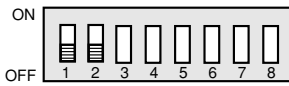

Operation	SW1	SW2
Ondelay	OFF	OFF
Offdelay	OFF	ON
One-shot	ON	OFF
Accumulation	ON	ON

※ Factory setup

Time range

The time range is selected with Dip switches 3, 4, and 5. The time range for items not present can be selected in Setup mode.



Time range	SW3	SW4	SW5
□.□□□s	OFF	OFF	OFF
□□.□□s	OFF	OFF	ON
□□□.□s	OFF	ON	OFF
□□□□s	OFF	ON	ON
□□m□□s	ON	OFF	OFF
□□□□m	ON	OFF	ON
□□□□h	ON	ON	OFF
□□h□□m	ON	ON	ON

※ Factory setup

h: hours m: minutes s: seconds

Display format

The display format is selected with Dip switch 6.

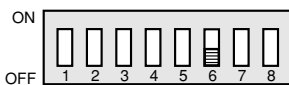

Input mode	SW6
Input for Addition or Subtraction	OFF
Dual input	ON

※ Factory setup

Key protection

With Dip switch 7, [Do not protect keys] can be selected to take effect for keys set in Setup mode using [Protect keys]. Setting for keys to protect can be performed in Setup mode. When this switch is ON, re-supplying power will cause protection to take effect. As the factory setup, [Do not protect keys] is set.



Key protection	SW7
Settings in Setup mode do not take effect	OFF
Do	ON

※ Factory setup

Operating mode

The operating mode is selected with Dip switch 8.

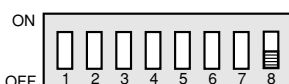

Operating mode	SW8
Run mode	OFF
Setup mode	ON

※ Factory setup

Setup Mode

Settings that cannot be selected with dip switches can be set in Setup mode.

Items that can be configured in Setup Mode

- (1) Start input response — 1/5/15 ms
- (2) Input logic — Positive or negative logic
- (3) Output mode — Flicker mode, dip switch
- (4) Time range — 0.0 m/0.0 h, dip switch
- (5) Output duration — Duration of output in Blink mode can be set from 10~9990 ms (in 10-ms increments)
- (6) Alarm output — Offset values can be set with respect to preset values.
- (7) Resetting key protection — Setting to disable the reset key can be performed.
- (8) Protecting digit keys — Setting to disable the arbitrary digit key can be performed.

1. Switching Between Setup mode and Run mode

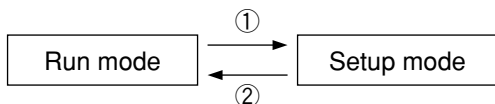

- ① Setting Dip switch 8 to ON and turning on the power will start the Setup mode.
- ② Setting Dip switch 8 to OFF and turning on the power will start the Run mode.

2. Operations in Setup mode

In Setup mode, the count can be initialized using the menu as follows:

* Represents factory setups.

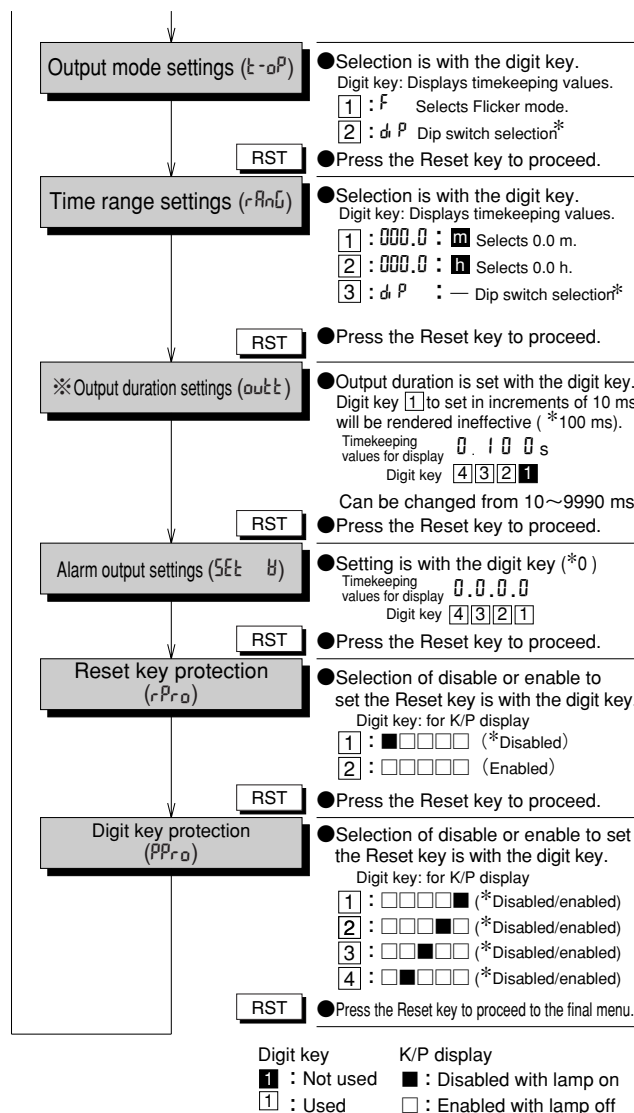
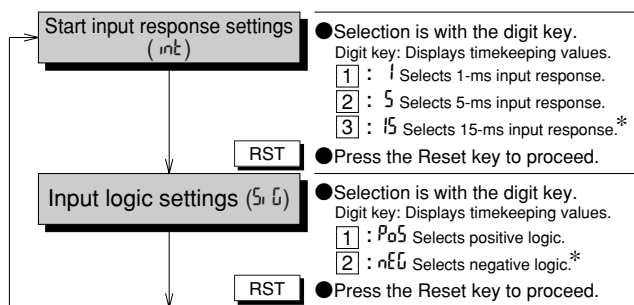

- In Flicker mode, items marked with an ※ are skipped.
- After changing the default settings in Setup mode, press the **RST** key in Run mode and reset timekeeping values.
- Setting parameters are rendered effective by pressing the **RST** key and proceeding to the next step.
- Key protection settings are rendered effective with Dip switch 7 as well as an AND condition. To begin protection, turn Dip switch 7 ON.

Operational Example

Changing preset values

1. Change the preset value from 2:00 to 1:30

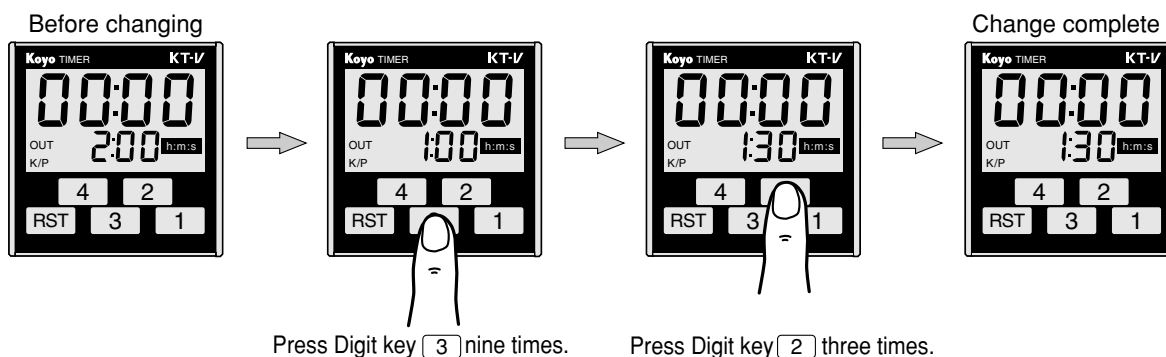

Washing Time Control

After pressing the start switch, washing will be performed for the set time.

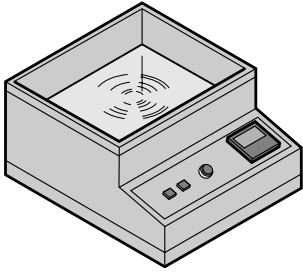

Set item	Details
Output mode	One-shot
Time range	□□m□□s
Display format	Remaining time
Key protection	Reset key } Disabled s key }

1. Setting Dip switches

Operate Dip switches with the power off.

① Select Output mode and One-shot.

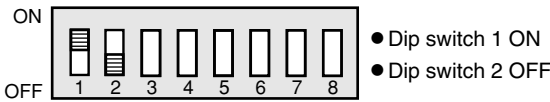

② Select the time range in □□ m □□ s.

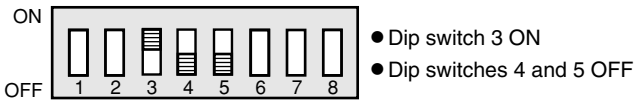

③ Select Key protection.

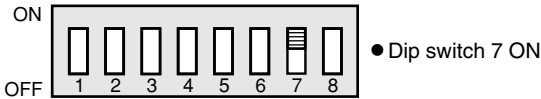

2. Switching to Setup mode

Turn Dip switch 8 ON and then turn power ON.

3. Changing setting contents

① The setting screen for Start input response is displayed.

These values are initial values.

Press the **RST** key to proceed.



② The setting screen for Input logic is displayed.

These values are initial values.

Press the **RST** key to proceed.



③ The setting screen for Output mode is displayed.

These values are initial values.

Press the **RST** key to proceed.



④ The setting screen for Time range is displayed.

These values are initial values.

Press the **RST** key to proceed.



⑤ The setting screen for Alarm output is displayed.

These values are initial values.

Press the **RST** key to proceed.



⑥ The setting screen for Reset key protection is displayed.

These values are initial values.

Press the **RST** key to proceed.



⑦ The setting screen for Digit key protection is displayed.

Press the **4** key and **3** key to permit key protection.

Press the **RST** key and the setting parameters will be written.



4. Switching to Run mode

Turn the power OFF after completing setting in Setup mode and turn Dip switch 8 OFF (Run mode); then turn power ON.

5. Starting Run mode

Be sure to turn power ON after changing settings in Setup mode and press the **RST** key to reset count values.

Precautions

●Precautions for Use

- (1) With the DC power source, the 0-V terminal ⑫ and the input common 0-V terminal ⑤ are internally short-circuited.
- (2) Apply the rated voltage in one instant, not by gradually raising the voltage.
- (3) Always use negative input logic to set the DC 2-wire proximity switch.
- (4) During counting, changes to preset values will take effect about one second after key input of the change. In subtraction mode, key input takes effect when the count is reset valid preset value will be saved in the memory at loss of power.
- (5) It is recommended to use a sheet included in the package to keep the setups for the future maintenance.
- (6) Use in the following environments should be avoided:
 - A location where the ambient temperature is above 50°C or below 10°C.
 - A location where the ambient humidity is above 85% or abrupt temperature changes may cause condensation.
 - A location with dust, iron fillings, corrosive gasses, or the like.
 - A location exposed to direct sunlight.
 - A location with significant vibrations or impact.
- (7) When conducting testing of insulation withstand voltage, insulation resistance, or the like, detach the control circuit from the main body.
- (8) When power is interrupted, writing to the internal EEPROM will take place. The number of times EEPROM writing can be performed is less than 10000, so avoid use with frequent power source operation.

●Precautions for Wiring

- Keep the wires away from power line.
- With regard to use in locations where extensive noise is generated, keep the KT-V timer and wires away from the noise source to the extent possible.
- Empty terminals are not to be used as relay terminals.
- For connection, use of crimped contacts is recommended. When wiring the 1 and 7 terminals, do not install fork-shaped crimped contacts at an angle. Use a round crimped contact for angled installation.

Fork-shaped crimped contacts

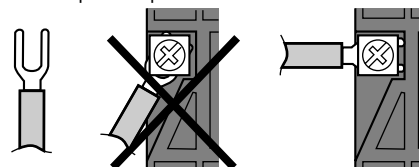

For angled installation, connection with the contact is insufficient. Like in the illustration above, install the contact perpendicular to the horizontal.

Round crimped contact

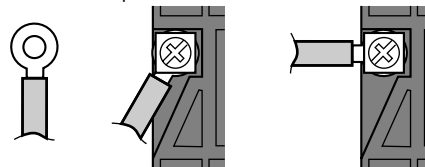

Installation and Removal of the Main Body

●Installation

- ①Insert the main body through the panel installation port.

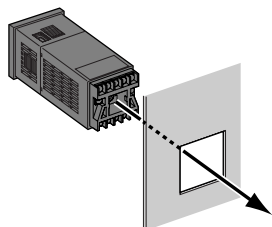

- ②From the rear, mount the installation frame.

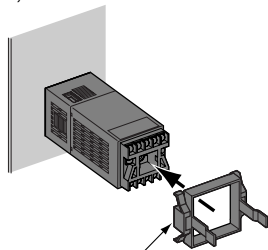

Installation frame: Can be installed vertically or horizontally.

●Removal

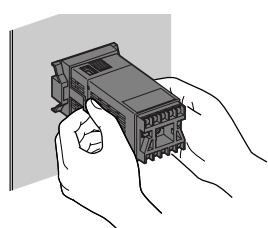

- ①Holding the tabs, spread them 2~3 mm.
- ②While keeping the tabs spread, pull the device towards you.

●Installation of the Terminal Block and Terminal Cover

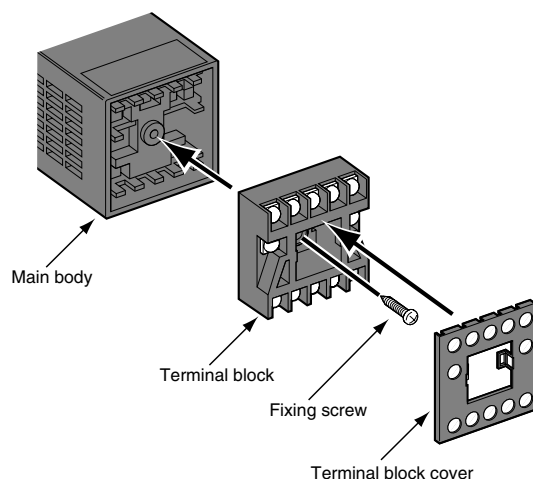

- Do not use a screw other than the one used to fix the terminal block during shipping.
- Maintain a permitted torque of 0.3 Nm.
- Install the terminal block after wiring is complete.

KT-V

Error Codes

Common Errors

Error	Error type	Error details	Corrective Action
E21	Memory data error	Preset/set values and Setup mode items have changed.	Press the Reset key to eliminate the error display. Measurement values and timekeeping values will be set to 0, preset and set values will be 5000, and Setup mode contents will be set to the factory setups.

Options

Option	Model Number	Details
Rubber packing	KC-48P	Prevents water from entering the control panel with installation between the installation panel and TC-V or KT-V.
Front cover	KC-48C	Protects the front panel from dirt and the like. Material: Soft silicone rubber Key operation can be performed with the front cover as-is.

External Dimensions

(in mm)

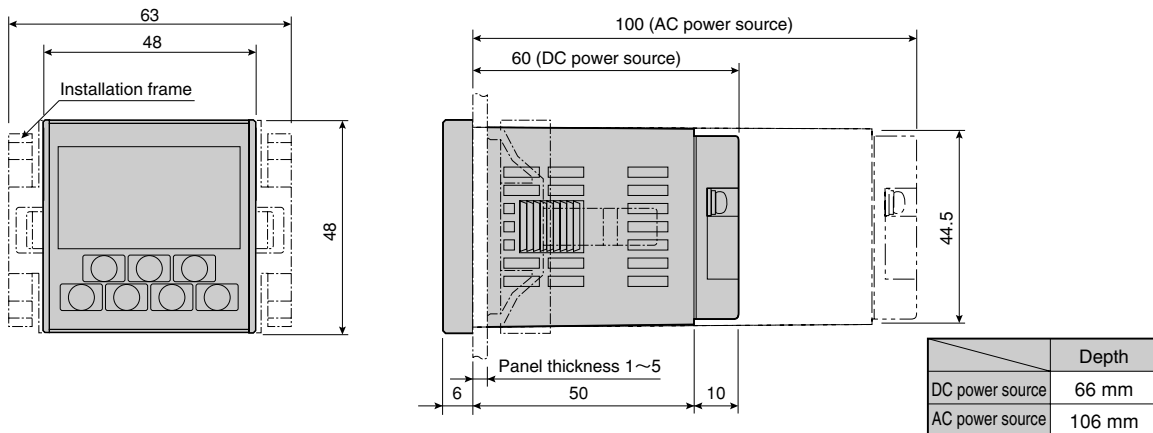

Detailed Diagram of the Terminal Block

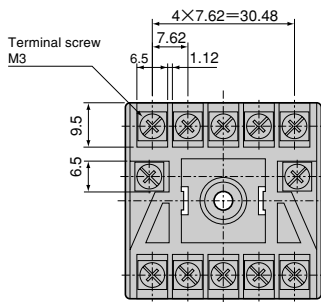

Complying wiring: 0.25-1.65 mm²
 Complying crimped contact: R1.25-3
 Permitted torque: 0.5 Nm

Boring Dimensions for Installation

1. When the installation handle is horizontal

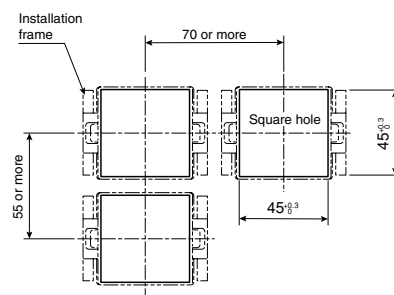

2. When the installation handle is vertical

