

TC Series

Digital Tachometers

Merits

● Prescaling

Based on a preset scale, the tachometer converts the number of revolutions to a distance, volume or production per unit time. The prescale function is not included in the TC-4L model.

● Precision

Using a sampling technique, the tachometer precisely measures various speeds and cycles of repeated movements

● Quick reset (TC-41)

On the TC-41 model, the displayed value is reset to zero if no pulse is entered for one second. The counter displays the previous value if it receives no pulse for six seconds.



List of Digital Tachometers

| | Signal output | | | Signal input | Functions | | | | |
|-------|---------------------|-----------|---------------|----------------------|-----------------------|-------------|-----------|---------------|--------------|
| | None (Display only) | Digital | Single preset | | Mode | Pre-scaling | Sam-pling | Decimal point | Error report |
| TC-4L | | — | — | | Mode 1 only | — | — | ● | ● |
| TC-4 | | TC-4B | TC-4S | | 8 modes | ● | ● | ● | ● |
| TC-41 | | — | — | Any types of sensors | Mode 1 only * 4 modes | ● | ● | ● | ● |

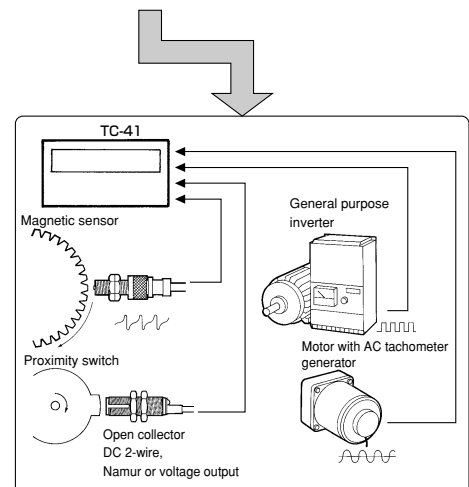
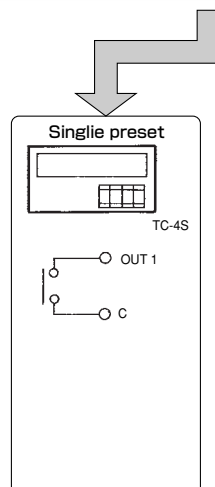
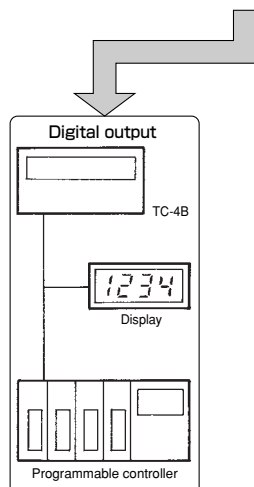

Measurement examples

Eight measurement modes and examples

Revolutions (rpm) (Mode 1)

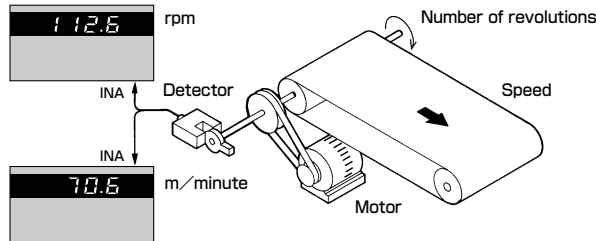

Based on the pulse input from the detector, the tachometer calculates and displays the number of revolutions per minute (rpm).

Using the prescale, it converts the number of revolutions to a speed then displays the value. $Speed = \text{number of revolutions} \times 2\pi r$ (r is the radius of the roller in meters.)

Speed (Mode 1)

Passing speed (Mode 2)

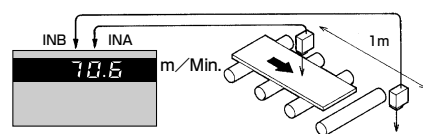

Using two detectors, the tachometer measures the speed of an object passing through a certain point. The prescale can be adjusted to suit the measurement unit.

Cycle time (Mode 3)

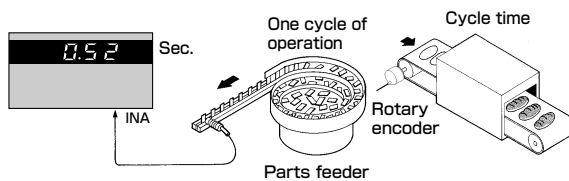

The tachometer measures the time for an object to pass through a certain distance.

Cycle measurement range 10ms~140s

Time elapsed: Infinite

Time lag (Mode 4)

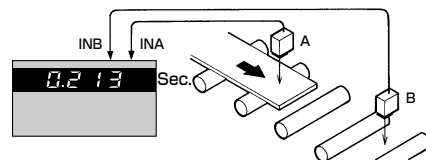

The tachometer measures the time for an object to move from the detector A to the detector B. Its speed can be calculated from the "time lag" between the two sensors and their distance.

Cycle measurement range 10ms~140s

Process time (Mode 5)

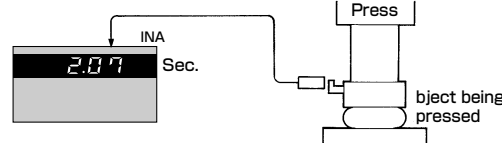

The tachometer displays the time elapsed after an action is started. For example, it measures the time after a press is started or a valve is opened.

Cycle measurement range 10ms~140s

Length (Mode 6)

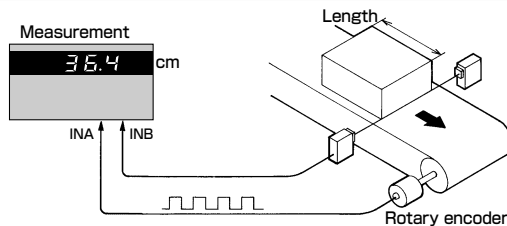

The photoelectric sensor generates pulse when it detects a moving object. The pulse count is converted to the length by the rotary encoder, and displayed on the tachometer. With the prescaling function, the measurement can be converted at a preset scale.

Spacing (Mode 7)

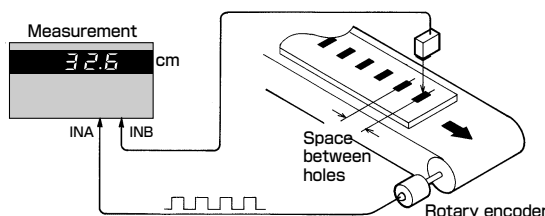

The tachometer measures and displays the space between two adjacent objects (in this case holes). With the prescaling function, the measurement can be converted at a preset scale.

Accumulate (Mode 8)

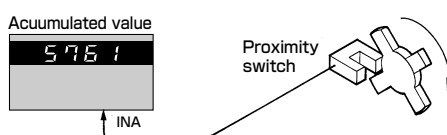

The tachometer totals individual pulse counts. It can be used also as a preset counter. With the prescaling function, the measurement can be converted at a preset scale.

Digital Tachometers
TC-V
TC-4L
TC-41
TC-4
TC-4B
TC-4S

TC Series

Merits

Prescaling

Prescale a 4-digit value to determine the scale used to calculate values for display.

To preset a scale, use the five small rotary switches on the rear panel.

Measurement \times Prescale = Value to be displayed

Set the scale in the form of " $M \times 10^{-n}$ " where M is a 4-digit integer and n is a number from 0 to 9. Use the leftmost switch to set the exponent n, and the other four switches to set the value of M. The prescale can range from 1×10^{-9} to $9999 \times 10^0 = 9999$.

Prescaling is not available on the TC-4L model.

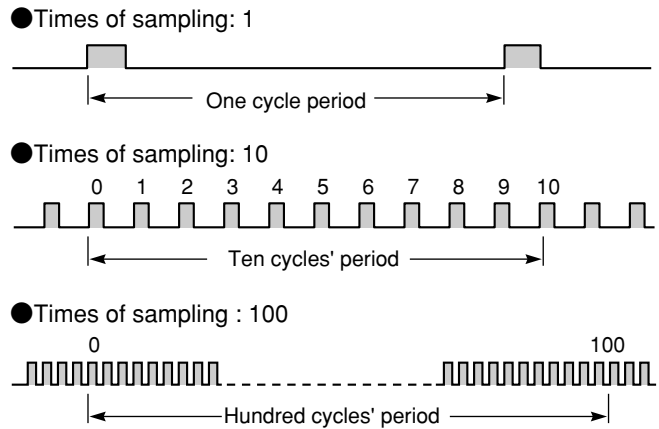
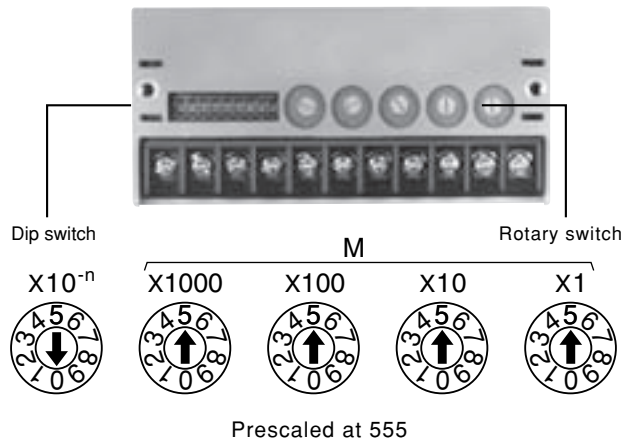

Sampling This function is available only in Mode 1.

The tachometer counts the cycle time of a rotating object. Using this value, it calculates the number of revolutions per minute. When an object rotates fast, one cycle period becomes too short to allow precise measurement. The tachometer samples a specified number of cycles and totals all cycle periods. From this total, it then calculates one cycle period. This averaging technique minimizes errors at high speeds. The times of sampling can be set to 1, 10 or 100. (Only 1 can be selected on the TC-4L model.)

Decimal point Selection

For the 4-digit display, you can select the location of the decimal point. Measurements are displayed to a precision specified by the decimal point.

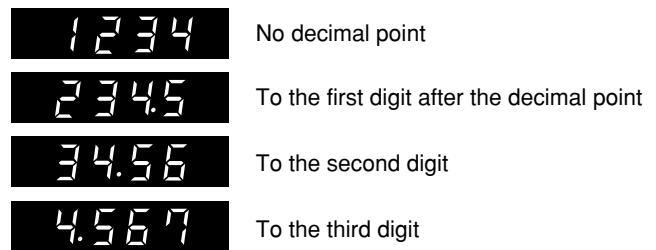

List of Error Codes

An error code is displayed to indicate an overflow, prescale error, or other error as shown on the right.



| Error code | Name | Description |
|------------|----------------|--|
| E01 | Overflow | Measurement has exceeded upper limit. |
| E02 | Underflow | Measurement is smaller than the value representable by the lowest digit. |
| E03 | Prescale error | The integer part (M) is set to zero. |
| E04 | Overfrequency | Input frequency has exceeded 10 kHz in Mode 1. |

Note: The errors E01, E02 and E04 are automatically cleared when the value returns to the allowable range.

Measurement modes

Mode 1: Number of revolutions(rpm)

The following description does not apply to TC-61 and TC-41.
The TC-4L model does not have the input terminal IN B.

The tachometer calculates the number of revolutions(rpm)by multiplying the inverse of the cycle period(T)of IN A by 60, and displays the result. When IN B turns ON, the tachometer stops measurement and retains the previous value.

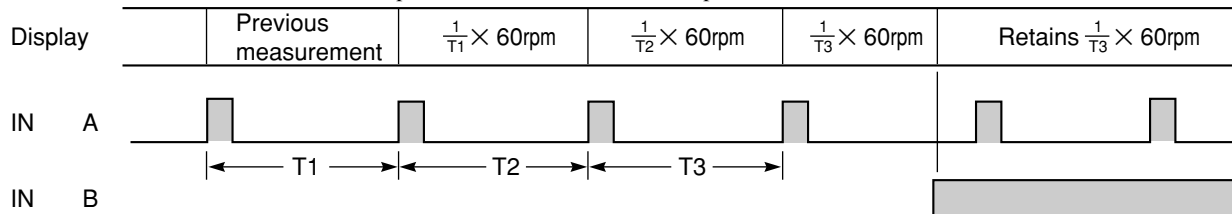

Measurement range: 10 to 9999 rpm(at input rate=1 pulse/revolution, times of sampling=1, and prescale=1)
Measurement is made for each cycle only if the cycle period is 300 ms or more. If not, the counter waits for at least one cycle before it restarts measurement. It displays the previous value if no pulse is entered for six seconds.

Mode 2: Passing speed (m/min.)

The tachometer calculates the speed of an object by multiplying the inverse of the value T by 60. T is time elapsed after the sensor IN A turns ON until the sensor IN B turns ON. The speed is displayed in meters per minute if the distance between the two sensors is 1 m.

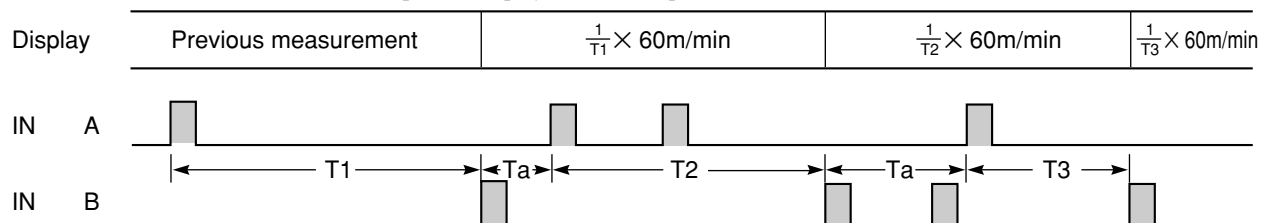

T: 10 ms~6 seconds. Ta: 30 ms interval between measurements

Mode 3: Cycle time (10 ms to 140 s)

The tachometer calculates the cycle period (T) of IN A.

It measures every other cycles ranging from 10 ms to 140 seconds.

When IN B turns ON, the tachometer stops measurement and retains the current value.

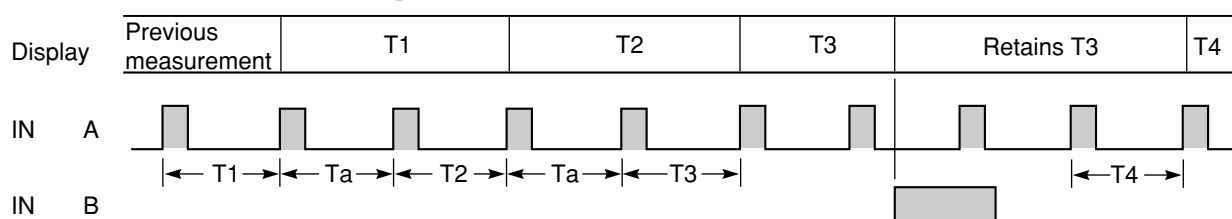

Ta: 30 ms interval between measurements

Mode 4: Time lag (10 ms to 140 s)

The tachometer measures the time elapsed after the sensor IN A turns ON until the sensor IN B turns ON.

Allowable measurements range from 10 ms to 140 seconds.

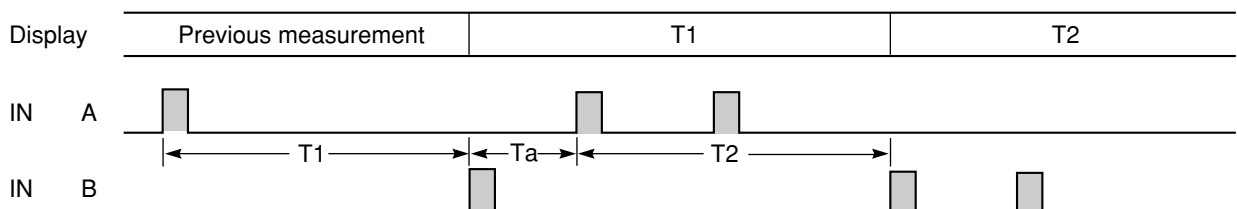

Ta: At least 30 ms interval between measurements

Digital Tachometers
TC-V
TC-4L
TC-41
TC-4
TC-4B
TC-4S

TC Series

Mode 5: Process time (10 ms to 140 s)

The tachometer displays the time elapsed after the sensor IN A is activated.
 Allowable measurements range from 10 ms to 140 seconds.
 When IN B turns ON, the tachometer stops measurement and retains the current value.

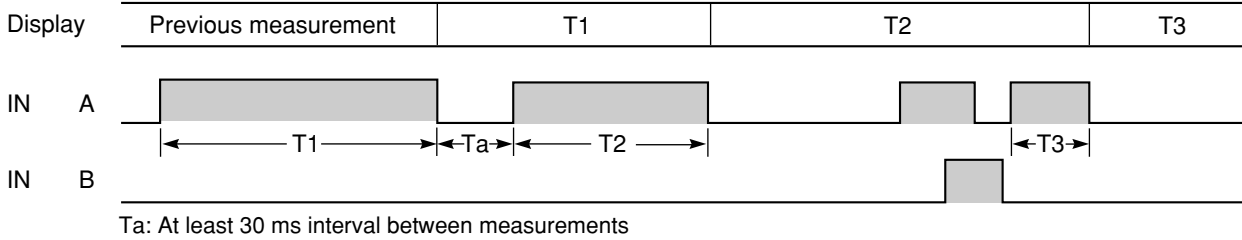

Mode 6: Length

Response of IN A: 10k cps

While IN B is ON, the tachometer counts the frequency of pulse entered to IN A.
 The value is displayed when IN B turns off. It is reset to zero when a reset signal is entered.

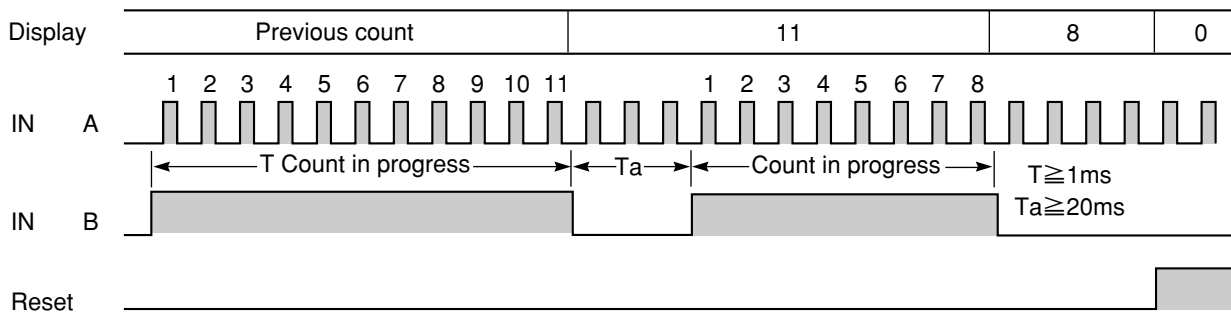

Mode 7: Spacing

Response of IN A: 10k cps

When IN B turns ON, the tachometer counts the frequency of pulse entered to IN A since the last time IN B turned ON.
 The value is reset to zero when a reset signal is entered.

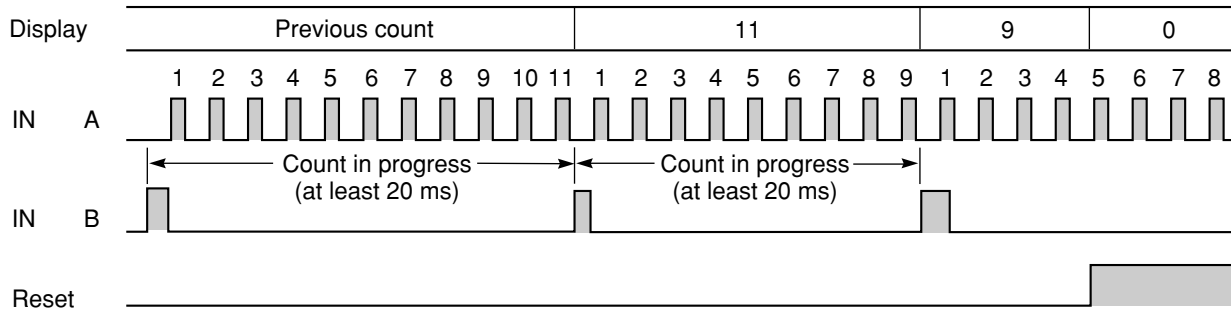

Mode 8: Accumulate

Response of IN A: 10k cps
 (150 cps on TC-4S and 4W in One Shot mode)

The tachometer totals and displays pulse counts entered to IN A.
 The count is suspended when IN B turns ON.
 The displayed value is reset to zero when a reset signal is entered.

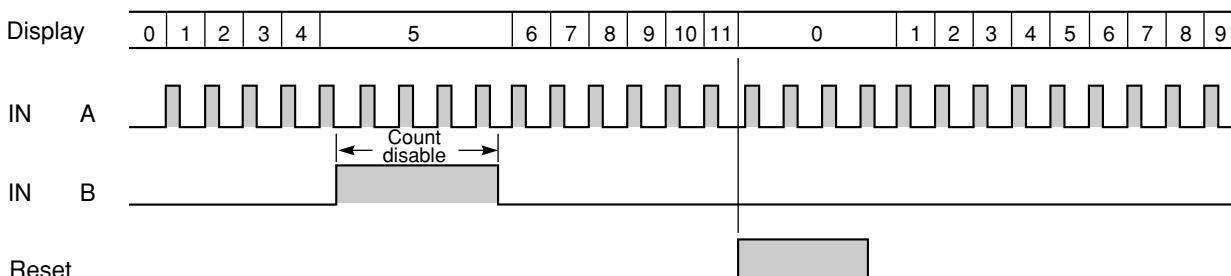

TC-4L-G/H

Power-Saving Small Tachometers for Display Only

On the 48 mm square panel, the tachometers displays revolution speeds. The input rate can be set to either one pulse or ten pulses per revolution.



- TC-4L-G : AC110V(AC85~115V 50/60Hz)
- TC-4L-H : AC220V(AC180~240V 50/60Hz)

General Specifications

● Electrical specifications

| Item | Specification |
|-----------------------|---|
| Rated voltage | TC-4L-G : AC85~115V TC-4L-H : AC180~240V |
| Rated frequency | 50/60Hz |
| Power consumption | 6VA |
| Withstand voltage | AC2000V 1 Min. (between power and external terminal) |
| Insulation resistance | Min. 20MΩ DC500V (between power and external terminal) |

● Environment

| Item | Specification |
|--------------------------|--|
| Ambient temperature | -10~+50°C |
| Storage temperature | -25~+70°C (with no freezing) |
| Ambient/Storage humidity | 35~90%RH (with no dewing) |
| Vibration resistance | Durable along three axes at 10 to 55 Hz with 0.5 mm amplitude No error along three axes at 10 to 55 Hz with 0.35 mm amplitude |
| Shock resistance | Durable for 11 ms along three axes at 490 m/s ² (50 G) No error for 11 ms along three axes at 98 m/s ² (10 G) |
| Noise resistance | 1 kV 1 μs between power terminals |

Mechanical and Performance Specifications

| Item | Specification |
|-----------------------|---|
| Measurement method | Cycle period measurement |
| Function | Display only |
| Display interval | Every 0.4 second if input pulse cycle is 0.4 second or less. Otherwise, 0.4 second plus cycle period. Previous value is displayed for six seconds after the object stops revolution. |
| Screen | 7-segment red LED for 4-digit display (Character height: 8 mm) |
| Measurement range*1 | 10~9999rpm |
| Precision | ±1 digit |
| Available measurement | Number of revolutions per minute (Mode 1 only) |
| Prescaling | 1 or 10 pulses/revolution*2 |
| Times of sampling | 1 |
| Installation | Socket B or F using optional |
| Sensor power | DC12V 30mA |
| Power-on reset | Shutdown period: 0.5 second Reset period: 0.5 second |
| External dimensions | 48W×48H×95D |
| Weight | Approx. 200 g |
| Accessory | Metal fitting |

*1 When prescale is 1.

*2 The pulse rate per revolution can be set to either 1 or 10.

| Measurement range | Input pulse rate | Switch 4 at Position A | Position B |
|---------------------|--------------------|------------------------|------------|
| | 1 pulse/revolution | 10~999 rpm | one tenth |
| 10 pulse/revolution | ten fold | 1~9999rpm | |

Input

| Terminal number | Signal | Name | Specification | | | |
|-----------------|--------|-------|------------------|-------------|---------|--------|
| | | | Response | Resi-stance | Voltage | |
| | | | | | ON | OFF |
| 6 | IN | Input | 10 cps or 2k cps | 1kΩ | 0~4V | 10~30V |

Input pulse width

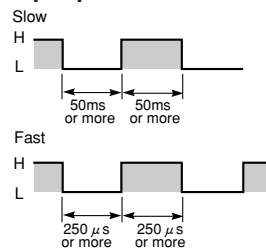

Input circuit

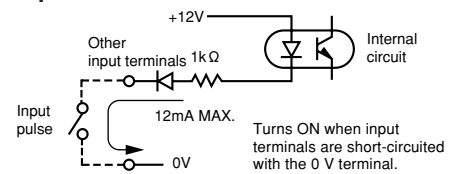

Switches

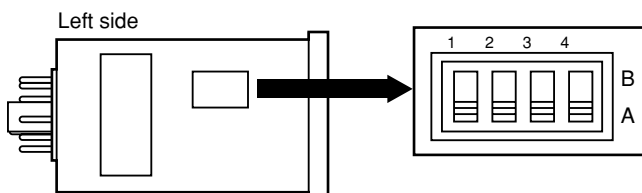

| Switch | Used to select | at Position A | at Position B |
|--------|------------------------|---|----------------------|
| 1 | Count speed | 2kcps | 10cps |
| 2 | Decimal point location | See the table below for the locations selected by different combinations of the switches. | |
| 3 | Decimal point location | | |
| 4 | Input pulse rate | 1 pulse/revolution | 10 pulses/revolution |

Decimal point location

| Switch | 9999 | 999.9 | 99.99 | 9.999 |
|--------|------|-------|-------|-------|
| 2 | A | B | A | B |
| 3 | A | A | B | B |

Terminal Assignment

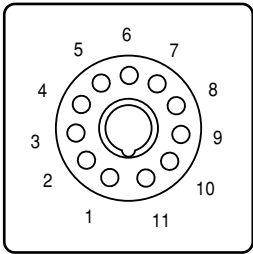

View for Rear side

| T/N | Description | T/N | Description |
|-----|--------------------|-----|--|
| 3 | 0V | 9 | Not connected |
| 4 | +12V(Sensor power) | 10 | |
| 5 | Not connected | 11 | |
| 6 | Input | — | ※110 V or 220 V depending on models ※Not connected for terminal No.11 |
| 7 | Not connected | 1 | |
| 8 | Not connected | 2 | |

Wiring examples

● Proximity switch

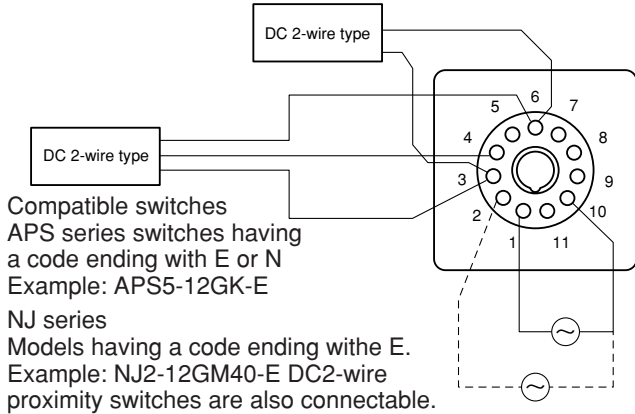

● Rotary encoder

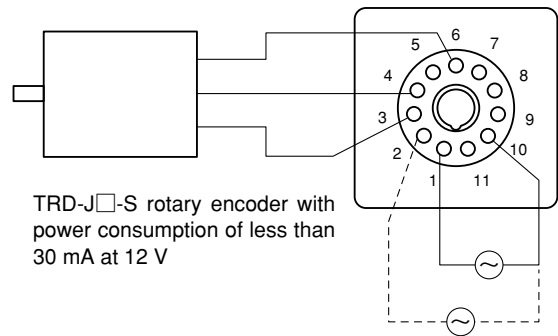

External Dimensions

(in mm)

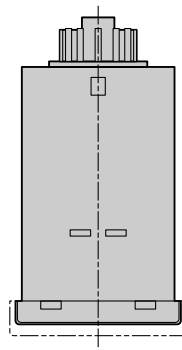
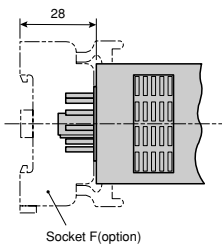

Boring dimensions for wall surface mounting

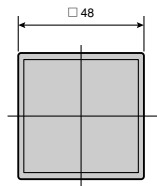
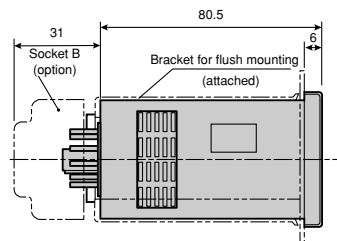
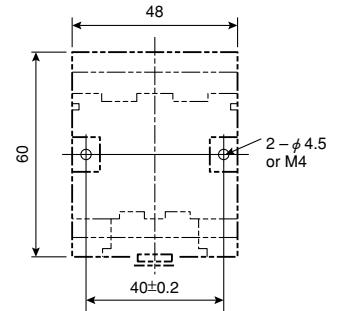

Boring dimensions for flush mounting

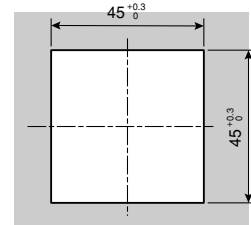

Specified sockets

(options)

For wall surface mounting using Socket F or DIN rails: KF-04

For flush mounting: KB-04

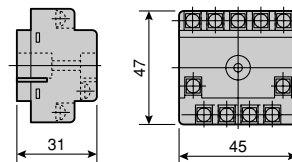
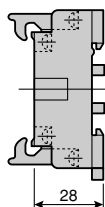
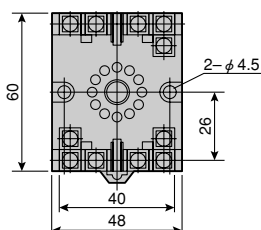

TC-41

Display Only Tachometers with Flexible Input Circuit

The display only tachometer features a special circuit to allow connection to any input device.

Displayed value is reset to zero if no pulse is entered for one second. Revolution speed is calculated from the average cycle period of pulse entered during one second. This minimizes the effect of speed variations. Available options include prescaling, sampling and decimal point display.



Operation

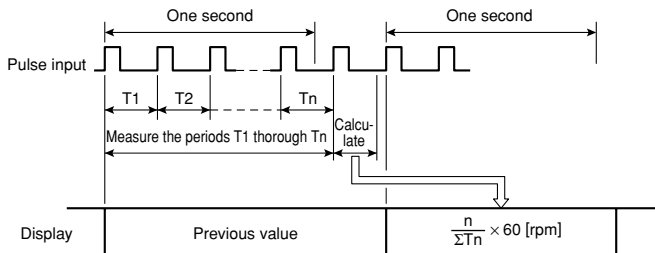

- When pulse rate per revolution=1, times of sampling=1, and prescale=1.
- When times of sampling=10 or 100, and 10 or 100 pulse period is shorter than one second.
- The above averaging is not performed if one cycle period exceeds one second, or if 10 or 100 pulse period is longer than one second.
- The displayed value can be reset to zero by input of an external signal.

General Specifications

●Electrical Specification

| Item | Specification |
|-----------------------|--|
| Rated voltage | AC90~132V / 180~264V |
| Rated frequency | 50 / 60Hz |
| Power consumption | 14VA |
| Withstand voltage | AC 2000 V for one minute between power and external terminal |
| Insulation resistance | Min. 20MΩ DC500V (between power and external terminal) |

●Environment

| Item | Specification |
|--------------------------|--|
| Ambient temp. | -10~+50°C |
| Storage temp. | -25~+70°C (with no freezing) |
| Ambient/Storage humidity | 35~90%RH (with no dewing) |
| Vibration resistance | Durable along three axes at 10 to 55 Hz with 0.5 mm amplitude No error along three axes at 10 to 55 Hz with 0.35 mm amplitude |
| Shock resistance | Durable for 11 ms along three axes at 490 ms ² (50 G) No error for 11 ms along three axes at 98 ms ² (10 G) |
| Noise resistance | 1 kV 1 μs between power terminals |

Mechanical and Performance Specifications

| Item | Specification |
|-----------------------|--|
| Measurement method | Cycle period measurement |
| Function | Display only, compatible to various inputs |
| Screen | 7-segment red LED for 4-digit display(Character height: 14.2 mm) |
| Measurement range | 10~9999 rpm / 60~9999 rpm |
| Precision | ±1 digit |
| Available measurement | Number of revolutions per minute (Mode 1 only) |
| Prescaling | $M \times 10^{-n} = 10^{-9} \sim 9999$ $1 \leq M \leq 9999, 0 \leq n \leq 9$ (where M and n are integers) |
| Times of sampling | 1, 10 or 100 (Mode 1 only) |
| Installation | Use screws and the terminal block on rear panel |
| Sensor power | DC12V 50mA |
| Power-on reset | Shutdown period: 0.5 second Reset period: 0.5 second |
| Output dimensions | 96W×48H×105D (mm) |
| Weight | Approx. 450 g |
| Accessory | Metal fitting |

Note: Averaging the pulse cycles per second minimizes variations of displayed value.

Compatible sensors and switches

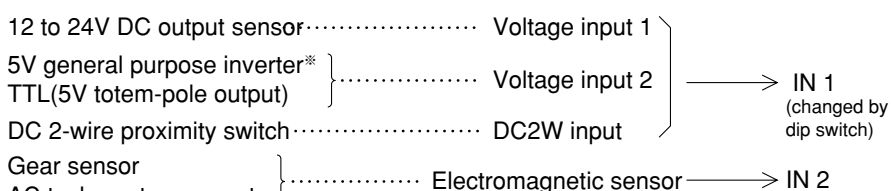

※To digitally display the speed of inverter motor, connect its pulse output to the TC-41 tachometer. Analog (voltage or current) signals cannot be used. The TC-41 circuit should be configured so as to accept the pulse to be counted.

IN 1 and IN 2 cannot be used at the same time.

Switches

The terminals and switches are located on the rear and the side of the tachometer.

Eight dip switches (8-bit) Rotary switches for prescaling

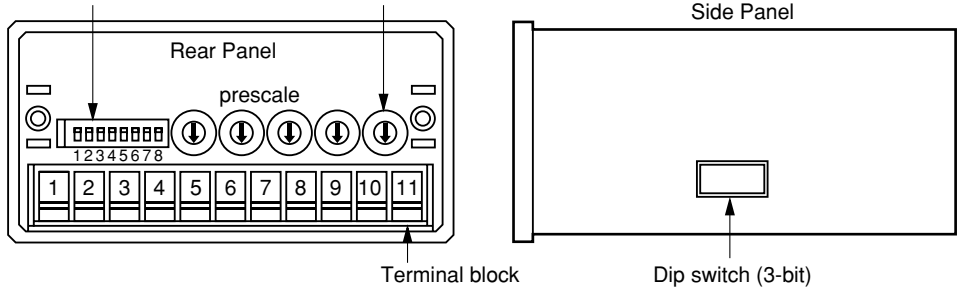

Prescaling

This function allow you to multiply the measured value by any value within the range shown below.

$$\text{Measurement} \times \text{Prescale} = \text{Value to be displayed}$$

Set the scale in the form of "M × 10ⁿ" where M is a 4-digit integer and n is a number from 0 to 9. Use the leftmost switch to set the exponent n, and the other four switches to set the value of M. The prescale can range from 1x10⁹ to 9999x10⁰=9999.

Notes:

- The exponent (10ⁿ) can be set in a range of 0 to 9.
- If you do not use a prescale, set the value to 1 (1 × 10⁰) = 1 as follows:

Prescaled at 1

* All the settings are 0 by the default.

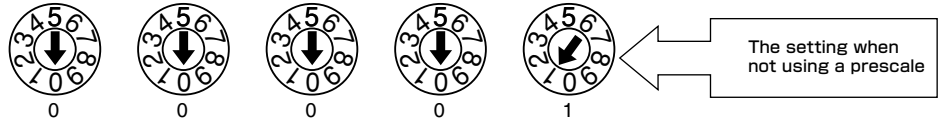

Eight dip switches on the rear panel

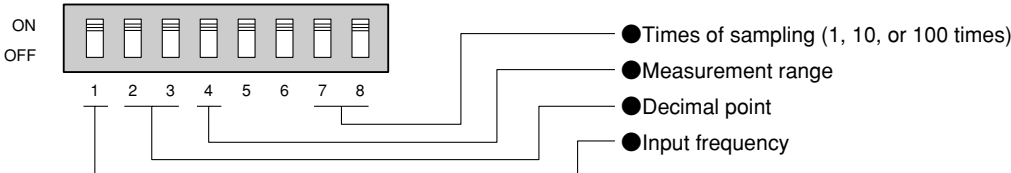

Switch 1: Input frequency (Count speed)

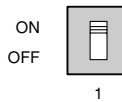

| | |
|-----|---|
| ON | 10 cps (Low speed) for both IN A and IN B |
| OFF | 10k cps (High speed) for both IN A and IN B |

Switches 2 and 3: Decimal Point

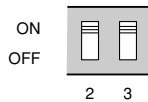

| Switch | 9999 | 999.9 | 99.99 | 9.999 |
|--------|------|-------|-------|-------|
| 2 | OFF | ON | OFF | ON |
| 3 | OFF | OFF | ON | ON |

Switch 4: Measurement range

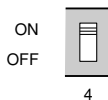

| | |
|-----|---|
| ON | 60 to 9999rpm* Reset to zero when pulse input is suspended for 1 second. |
| OFF | 10 to 9999rpm* Reset to zero when pulse input is suspended for 6 seconds. |

*When pulse rate per revolution=1, and prescale=1

Switches 5 and 6:

Switches 7 and 8: Time of Sampling



Unassigned

| Switch | 1 time | 10 times | 100 times |
|--------|--------|----------|-----------|
| 7 | OFF | ON | OFF |
| 8 | OFF | OFF | ON |

Dip switches on the side panel

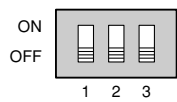

● Dip switch for selecting IN1 input mode

| | | | | |
|------------|--------------------|----------------|-------------------|-----------|
| Switch 1 | OFF | ON | OFF | OFF |
| Switch 2 | OFF | OFF | ON | OFF |
| Switch 3 | OFF | OFF | OFF | ON |
| Input mode | Voltage 1 (12~24V) | Voltage 2 (5V) | Current 1 (Namur) | Current 2 |

Input Specifications

| Terminal number | Name | Function | Specifications | | | | |
|-----------------|----------------------------------|--------------------------------------|-------------------|------------|---|---------|-------|
| | | | Response | Resistance | Voltage | | |
| | | | | | ON | OFF | |
| 2 | IN 1 Selected by dip switches | Voltage input 1 (12~24V) | 10cps or 10kcps | 15kΩ | 0~4V | 6~30V | |
| | | Voltage input 2 (5V) | | | 0~1.5V | 2.5~30V | |
| | | Current input 1 | | | 3.5kΩ *1 | 0~4V | 6~30V |
| | | Current input 2 | | | 1kΩ *1 | 0~4V | 6~30V |
| 3 | IN 2 | Electromagnetic detector pulse input | 10cps*2 or 10kcps | 10kΩ | 10cps: 0.3Vp-p or more 100cps: 0.3Vp-p or more 1kcps: 2Vp-p or more 10kcps: 20Vp-p or more | | |
| 4 | RESET | Reset input (open collector) | 30ms | 1kΩ *1 | 0~4V | 10~30V | |

Input pulse width

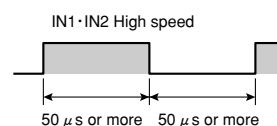
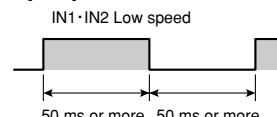

- *1. Pulled up to 12 V by internal circuit.
- *2. Use the dip switch 1 on the rear panel. Turn it to OFF to select 10kcps. IN 1 and IN2 cannot be used at the same time.

Circuit configuration

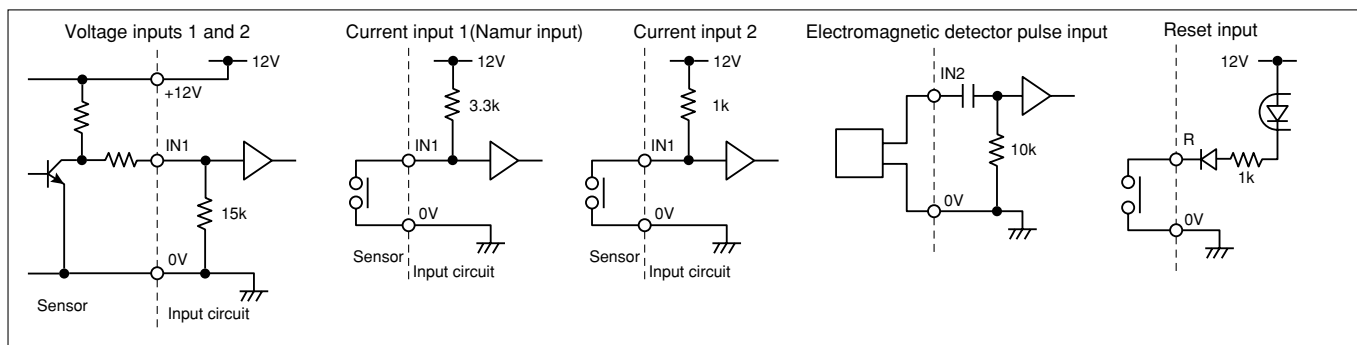

Terminal Assignment

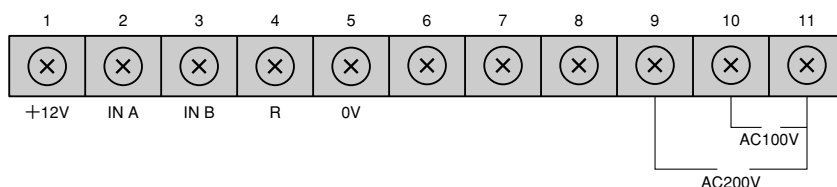

| Terminal number | Name | Description |
|-----------------|----------|---------------------------------|
| 1 | +12V | DC sensor power |
| 2 | IN 1 | Input |
| 3 | IN 2 | Input |
| 4 | R | Reset input |
| 5 | 0V | Common input: voltage and power |
| 6 | Not used | Not connected |
| 7 | Not used | Not connected |
| 8 | Not used | Not connected |
| 9 | AC200V | ACpower |
| 10 | AC100V | |
| 11 | AC0V | |

Digital Tachometers
TC-V
TC-4L
TC-41
TC-4
TC-4B
TC-4S

Wiring Examples

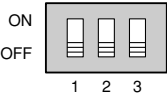
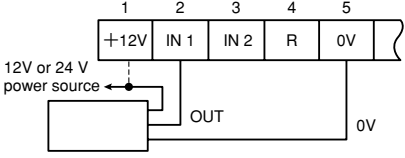
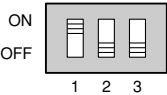
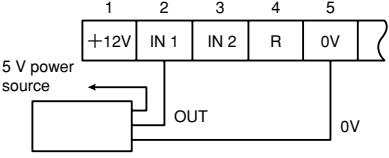
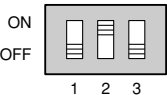
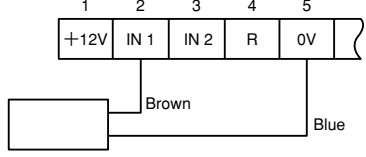
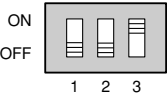
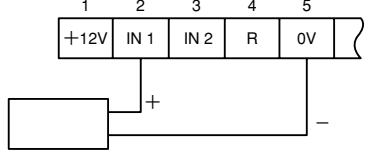
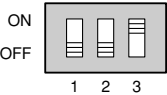
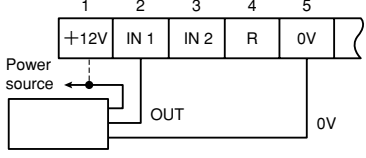
| Sensor | Input | Dip switches | Connection |
|--|------------------------------------|--|---|
| Proximity switch for voltage output (12 V to 24 V) Models: APS-80A-2T APS-30-2T | Voltage input 1 | ON OFF  |  |
| General inverter for voltage output(5V) TTL for totem-pole output | Voltage input 2 | ON OFF  |  |
| Proximity switch for Namur output The NJ type is turned OFF at detection time. | Current input 1 (Namur input) | ON OFF  |  |
| Sensor for current output Open collector and DC 2-wire proximity switch Models: APS3-12GMC-Z APS5-12GK-Z | Current input 2 | ON OFF  |  |
| Sensor for NPN open collector output Can be connected to Namur or current input Models: APS5-12GK-E/APS3-16F-E TRD-J <input type="checkbox"/> -S/RZ | Namur input or Current input | ON OFF  |  |

Notes:

- When using the +12 V sensor power, confirm that the sensor consumes less than 50 mA. This power is applicable to all the models listed above.
- To use IN 2 for electromagnetic detector, turn all the three switches on the side panel to the OFF positions.

(Example) Gear sensor,
AC tachometer generator,
etc.

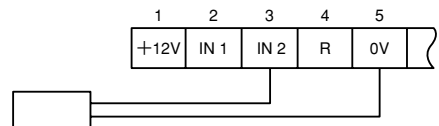
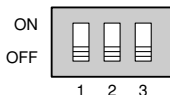

External Dimensions

(in mm)

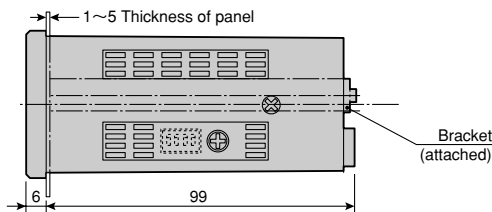
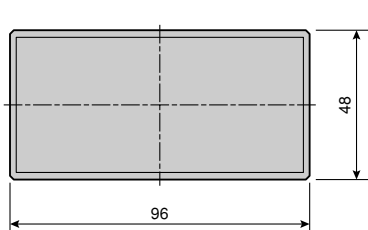

Boring dimensions

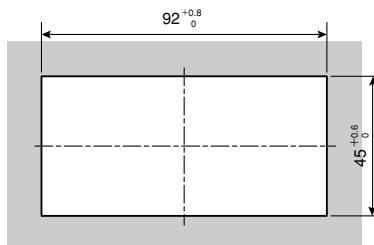

External dimensions of terminals block

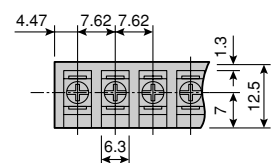

TC-4

Display Only Tachometer

The red LED screen clearly displays character of 14.2 mm in height. Eight modes are available for the following measurements: number of revolutions, speed, cycle time, time lag, process time, length, spacing, and total. Options include prescaling, sampling and decimal point display.



Displayed value is updated every 0.4 second when input cycle period is 0.4 second or less.

General Specifications

●Electrical specifications

| Item | Specification |
|-----------------------|--|
| Rated voltage | AC90~132V/180~264V |
| Rated frequency | 50/60Hz |
| Power consumption | 14VA |
| Withstand voltage | AC 2000 V for one minute between power and external terminal |
| Insulation resistance | Min.20MΩ DC500V (between power and external terminal) |

●Environmental specifications

| Item | Specification |
|--------------------------|--|
| Ambient temperature | -10~+50°C |
| Storage temperature | -25~+70°C (with no freezing) |
| Ambient/Storage humidity | 35~90%RH (with no dewing) |
| Vibration resistance | Durable along three axes at 10 to 55 Hz with 0.5 mm amplitude No error along three axes at 10 to 55 Hz with 0.35 mm amplitude |
| Shock resistance | Durable for 11 ms along three axes at 490 m/s ² (50 G) No error for 11 ms along three axes at 98 m/s ² (10 G) |
| Noise resistance | 1 kV 1 μs between power terminals |

Mechanical and Performance Specifications

| Item | Specification |
|------------------------|--|
| Measurement method | Cycle period based measurement |
| Function | Display only |
| Screen | 7-segment red LED for 4-digit display (Character height: 14.2mm) |
| Measurement range | 10~9999 rpm, 10ms~140s, 1~9999 counts |
| Precision | ±1 digit (Mode 1) or ±0.1ms (Modes 2 to 5) |
| Available measurements | 8 modes* |
| Prescaling | $M \times 10^{-n} = 10^{-9} \sim 9999$ $1 \leq M \leq 9999, 0 \leq n \leq 9$ (M and n are integers) |
| Times of sampling | 1, 10 or 100 (Available only in Mode 1) |
| Installation | Use screws and the terminal block on rear panel |
| Sensor power | DC12V 50mA |
| Power-on reset | Shutdown period: 0.5 second/Reset period: 0.5 second |
| External dimensions | 96W×48H×105D (mm) |
| Weight | Approx. 450 g |
| Accessory | Metal fitting |

* The following eight modes are available:
 Mode 1: Number of revolutions(rpm)
 Mode 2: Speed(meters/minute)
 Mode 3: Cycle time(seconds)
 Mode 4: Time lag(seconds)
 Mode 5: Process time(seconds)
 Mode 6: Length
 Mode 7: Spacing
 Mode 8: Prescale counter

Switches (rear panel)

The terminals and switches are located on the rear of the tachometer.

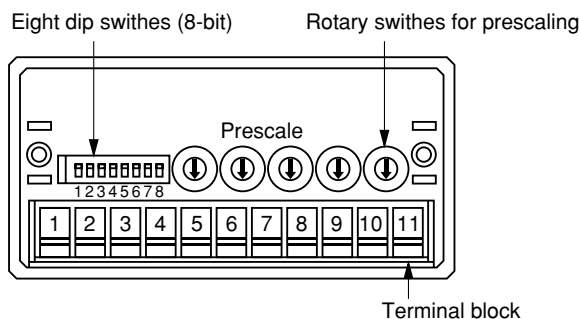

Prescaling

Preset a 4-digit value to determine the scale used to calculate values for display.

Measurement × Prescale = Value to be displayed

Set the scale in the form "M × 10⁻ⁿ" where M is a 4-digit integer and n is a number from 0 to 9.

Use the leftmost switch to set the exponent n, and the other four switches to set the value of M.

The prescale can range from 1 × 10⁻⁹ to 9999 × 10⁻⁰ = 9999.

Notes:

1. The exponent (10⁻ⁿ) can be set in a range of 0 to 9.
2. If you do not use a prescale, set the value to 1 × 10⁻⁰ = as follows.

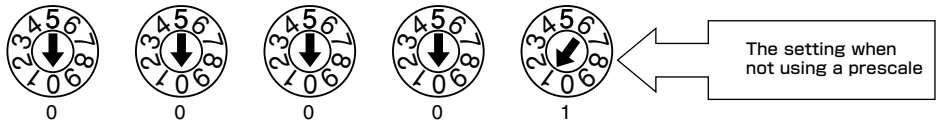
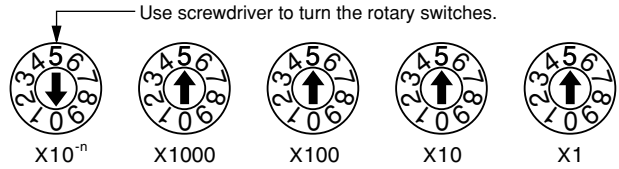

Eight dip switches on the rear panel

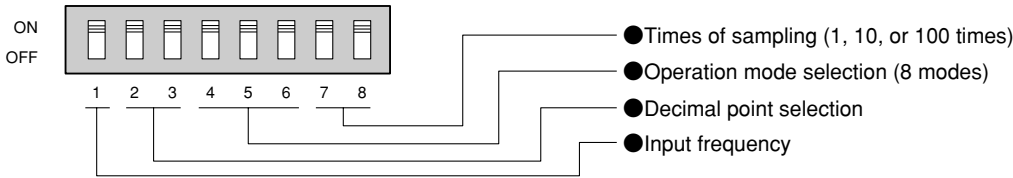

Switch 1: Input frequency (Count speed)

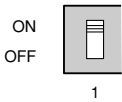

| | |
|-----|--|
| ON | 10cps for both IN A and IN B (Low speed) |
| OFF | 10kcps for both IN A and IN B (High speed) |

Switches 2 and 3: Decimal Point

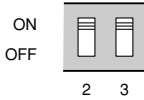

| Switch | 9999 | 9999 | 9999 | 9999 |
|--------|------|------|------|------|
| 2 | OFF | ON | OFF | ON |
| 3 | OFF | OFF | ON | ON |

Switches 4, 5 and 6: Measurement range

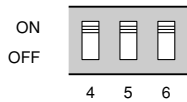

| Switch | Mode 1 | Mode 2 | Mode 3 | Mode 4 | Mode 5 | Mode 6 | Mode 7 | Mode 8 |
|--------|--------|--------|--------|--------|--------|--------|--------|--------|
| 4 | OFF | ON | OFF | ON | OFF | ON | OFF | ON |
| 5 | OFF | OFF | ON | ON | OFF | OFF | ON | ON |
| 6 | OFF | OFF | OFF | OFF | ON | ON | ON | ON |

Switches 7 and 8: Times of Sampling



| Switch | 1 time | 10 times | 100 times | |
|--------|--------|----------|-----------|----|
| 7 | OFF | ON | OFF | ON |
| 8 | OFF | OFF | ON | ON |

Input specifications

| Terminal number | Name | Function | Specifications | | | |
|-----------------|------|--------------|----------------------|------------|---------|--------|
| | | | Response | Resistance | Voltage | |
| | | | | | ON | OFF |
| 2 | IN A | Input | 10Hz/10kHz selection | 1kΩ | 0~4V | 10~30V |
| 3 | IN B | Input | | | | |
| 4 | R | Reset input* | 30ms | | | |

Not available in Modes 1 to 5

Input pulse width

INA · INB low speed

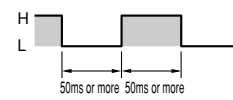

INA · INB high speed

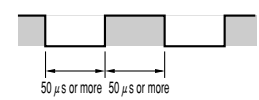

Circuit configuration

INA · INB · reset

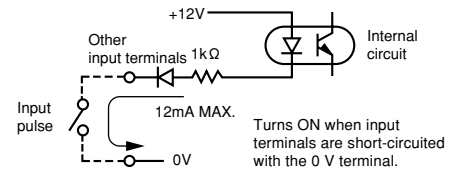

Terminal Assignment

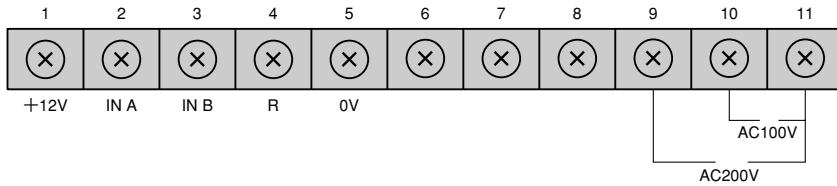

| Terminal number | Name | Description |
|-----------------|----------|---------------------------------|
| 1 | +12V | DC sensor power |
| 2 | IN A | Input |
| 3 | IN B | Input |
| 4 | R | Reset input |
| 5 | 0V | Common input: voltage and power |
| 6 | Not used | Not connected |
| 7 | Not used | Not connected |
| 8 | Not used | Not connected |
| 9 | AC200V | AC power |
| 10 | AC100V | |
| 11 | AC0V | |

External Dimensions

(in mm)

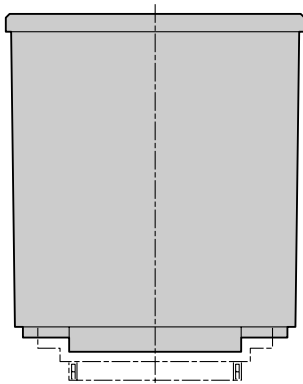
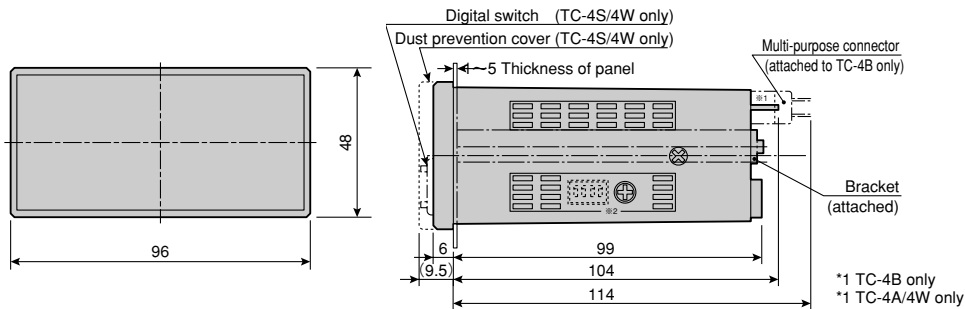

Boring dimensions

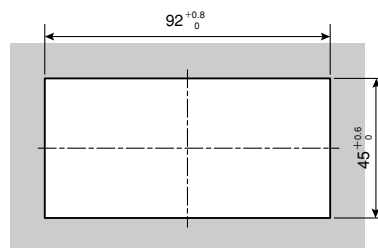

47×94 when the attached dust cover is used

External dimensions of terminal block

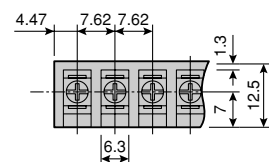

Digital Tachometers
TC-V
TC-4L
TC-41
TC-4
TC-4B
TC-4S

TC-4B

Tachometer with Digital Output

TC-4B provides features of digital output (BCD) on the base unit of TC-4.

The TC-4B gives the BCD output faster than displaying the value if input cycle period is 0.4 second or less.



For the General Specifications, see page C-33.

Mechanical and Performance Specifications

| Item | Specification |
|------------------------|--|
| Measurement method | Cycle period based measurement |
| Function | Digital output(BCD 4 digits) |
| Screen | 7-segment red LED for 4-digit display(Character height: 14.2mm) |
| Measurement range | 10~9999rpm, 10ms~140s, 1~9999 count |
| Precision | ±1 degit(Mode 1)or ±0.1ms(Modes 2 to 5) |
| Available measurements | 8 modes* |
| Prescaling | $M \times 10^{-n} = 10^{-9} \sim 9999$ $1 \leq M \leq 9999, 0 \leq n \leq 9$ (M and n are integers) |
| Times of sampling | 1, 10 or 100 (Available only in Mode 1) |
| Installation | Use screws and the terminal block on rear panel |
| Sensor power | DC12V 50mA |
| Power-on reset | Shutdown period: 0.5 second/Reset period: 0.5 second |
| External dimensions | 96W×48H×110D |
| Weight | Approx. 450 g |
| Accessory | Metal fitting (card edge connection) |

- *8 Modes
- Mode 1 : Number of revolutions (rpm)
 - Mode 2 : Speed (meters/minute)
 - Mode 3 : Cycle time (seconds)
 - Mode 4 : Time lag (seconds)
 - Mode 5 : Process time (seconds)
 - Mode 6 : Length
 - Mode 7 : Spacing
 - Mode 8 : Prescale counter

Switches (rear panel)

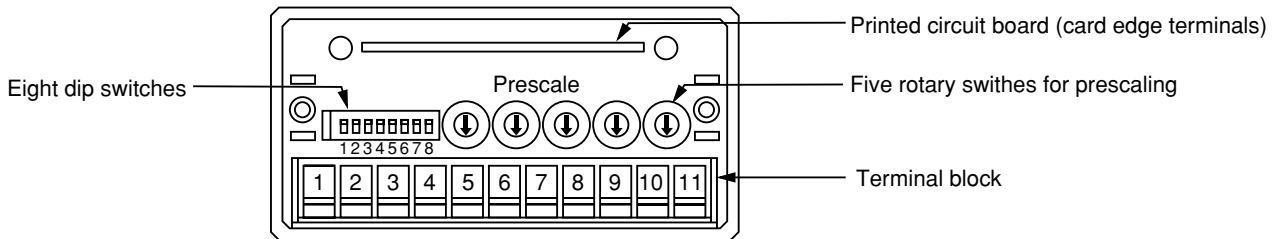

See page C-34 for how to operate these switches.

Input terminals

| Terminal number | Name | Function | Specifications | | | |
|-----------------|--------|---------------------------|----------------------|------------|---------|--------|
| | | | Response | Resistance | Voltage | |
| | | | | | ON | OFF |
| 2 | INA | Input | 10Hz/10kHz selection | 1kΩ | 0~4V | 10~30V |
| 3 | INB | Input | | | | |
| 4 | R HOLD | Reset input Hold input | 30ms | | | |

* Card edge terminal 10

Input pulse width

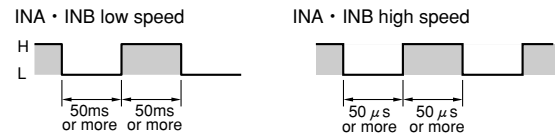

Input circuit configuration

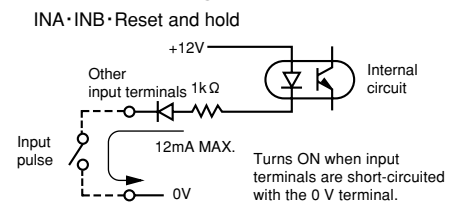

Output specifications

Output specifications

| | |
|------------------|--------------------------------------|
| Output type | Open collector |
| Operation | Turns on when resultant value is "1" |
| Voltage | Max. 24V |
| Current | Max. 30mA |
| Residual voltage | Max. 2V |

BCD and BUSY signals

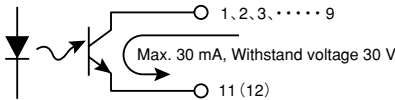

BCD output connection

Shunt the common input terminal 11 with the CH terminal 13 to separate the terminal 11 from the common output terminal 12.

More than one TC-4B tachometer can be connected to a programmable controller(PC). They can share BCD and BUSY terminals so the PC can be configured with 17 input terminals. A diode is required for each of BCD outputs and BUSY outputs.

Timing chart for BCD output with BUSY and HOLD signal. (example for Model 1)

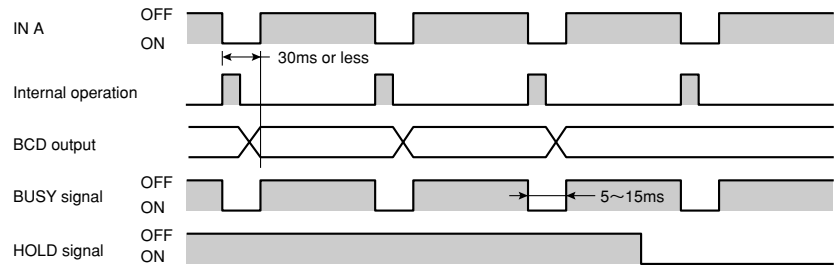

BCD value is not updated when HOLD signal is ON and BUSY signal is OFF. Data can be updated as long as BUSY signal is ON.

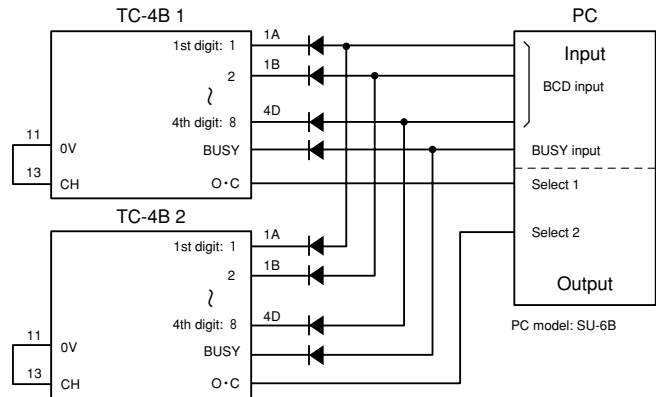

Terminal Assignment

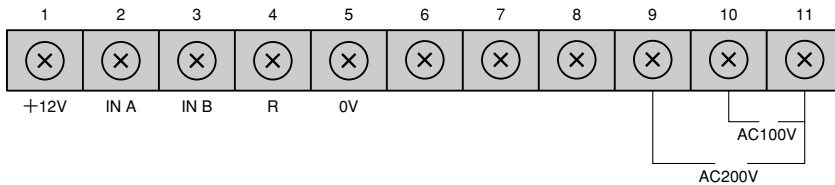

| Terminal number | Name | Description |
|-----------------|----------|--------------------------------|
| 1 | +12V | DC sensor power |
| 2 | IN A | Input |
| 3 | IN B | Input |
| 4 | R | Reset input |
| 5 | 0V | Common input voltage and power |
| 6 | Not used | Not connected |
| 7 | Not used | Not connected |
| 8 | Not used | Not connected |
| 9 | AC200V | ACpower |
| 10 | AC100V | |
| 11 | AC0V | |

Card edge terminals

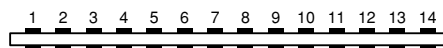

4-digit BCD values are generated through the card edge terminals as follows:

| Terminal name | B | 1A | 1B | 2A | 2B | 3A | 3B | 4A | 4B | BUSY | HOLD | 0V | O·C | CH | Unused |
|---------------|----------------------|---------|----|---------|----|---------|----|---------|----|--------|-------|--------|------------|---------------|--------|
| | A | 1C | 1D | 2C | 2D | 3C | 3D | 4C | 4D | BUSY | HOLD | 0V | O·C | CH | Unused |
| Signal | Upper edge(B) | 1 | 2 | 1 | 2 | 1 | 2 | 1 | 2 | BUSY | HOLD | 0V | O·C | CH | Unused |
| | Lower edge(A) | 4 | 8 | 4 | 8 | 4 | 8 | 4 | 8 | BUSY | HOLD | 0V | O·C | CH | Unused |
| | Destination/function | 1 digit | | 2 digit | | 3 digit | | 4 digit | | Output | Input | Common | OUT Common | O·C switching | |

Card edge terminal 11 is internally connected with Terminal 5 on the internal board.

Separating Terminal 11 and OUT Terminal 12

These terminals are internally connected. Short circuit the common input terminal 11 with the CH terminal 13 to separate the common input and common output.

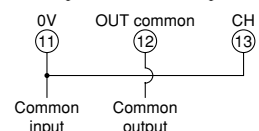

For the External Dimensions, see page C-27.

TC-4S Single Preset Tachometer

The TC-4S has a comparator function on the basic unit of TC-4. TC-4S is presettable and give output when the current value reaches the preset.



TC-4S

Mechanical and Performance Specifications

| Item | Specification |
|------------------------|--|
| Measurement method | Cycle period based measurement |
| Function | TC-4S: Single preset |
| Screen | 7-segment red LED for 4-digit display (Character height: 14.2mm) |
| Measurement range | 10~9999rpm, 10ms~140s, 1~9999 count |
| Precision | ±1 degit(Mode 1) or ±0.1ms(Modes 2 to 5) |
| Available measurements | 8 modes* |
| Prescaling | $M \times 10^{-n} = 10^{-9} \sim 9999$ $1 \leq M \leq 9999, 0 \leq n \leq 9$ (M and n are integers) |
| Times of sampling | 1, 10 or 100(Available only in Mode 1) |
| Installation | Use screws and the terminal board on rear panel |
| Sensor power | DC12V 50mA |
| Power-on reset | Shutdown period: 0.5 second/Reset period: 0.5 second |
| External dimensions | 96W×48H×105D |
| Weight | Approx. 450 g |
| Accessory | Metal fitting, dustproof cover |

For the General Specifications, see page C-25.

- * 8 Modes
- Mode 1 : Number of revolutions (rpm)
 - Mode 2 : Speed (meters/minute)
 - Mode 3 : Cycle time (seconds)
 - Mode 4 : Time lag (seconds)
 - Mode 5 : Process time (seconds)
 - Mode 6 : Length
 - Mode 7 : Spacing
 - Mode 8 : Prescale counter

Rear panel and Side panel

Eight dip switches (9-bit) Five rotary switches for prescaling

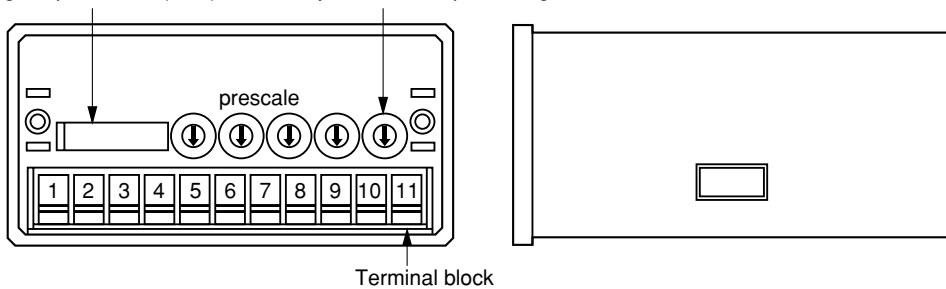

See page C-26 for how to operate these switches.

Dip switches on the rear panel

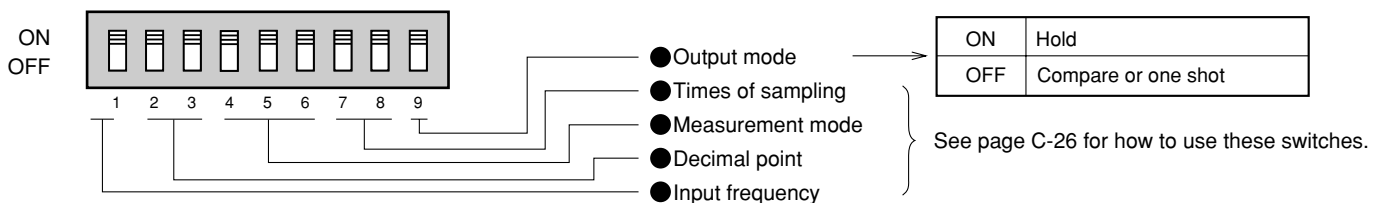

Input Specifications

| Terminal number | Name | Function | Specifications | | | |
|-----------------|------|--------------|-----------------|------------|---------|--------|
| | | | Response | Resistance | Voltage | |
| | | | | | ON | OFF |
| 2 | IN A | Input | 10cps or 10kcps | 1kΩ | 0~4V | 10~30V |
| 3 | IN B | Input | | | | |
| 4 | R | Reset input* | 30ms | | | |

*Not available in Modes 1 to 5.

Input pulse width

INA · INB low speed

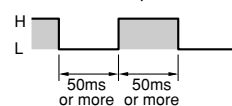

INA · INB high speed

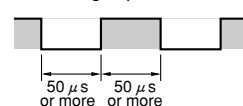

Input circuit configuration

INA · INB · Reset

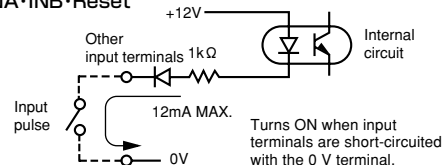

Output specifications

| Terminal number | Name | Function | Specifications | |
|-----------------|------|----------------|----------------|---|
| | | | Response | Contact capacity |
| 7 | OUT | Contact output | Max. 50ms | 200,000 contacts at 220V 2 A(resistance load) |

Output circuit

Relay output

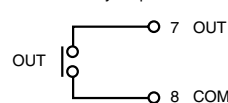

Terminal Assignment

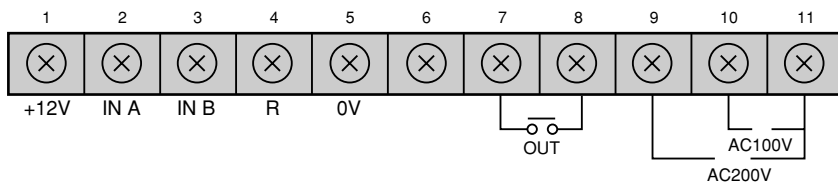

| Terminal number | Name | Description |
|-----------------|---------------|-----------------------------------|
| 1 | +12V | sensor power |
| 2 | IN A | Input |
| 3 | IN B | Input |
| 4 | R | Reset input |
| 5 | 0V | Common for input and sensor power |
| 6 | NC | - |
| 7 | OUT | Output |
| 8 | Common output | |
| 9 | AC200V | AC power |
| 10 | AC100V | |
| 11 | AC0V | |

Timing charts

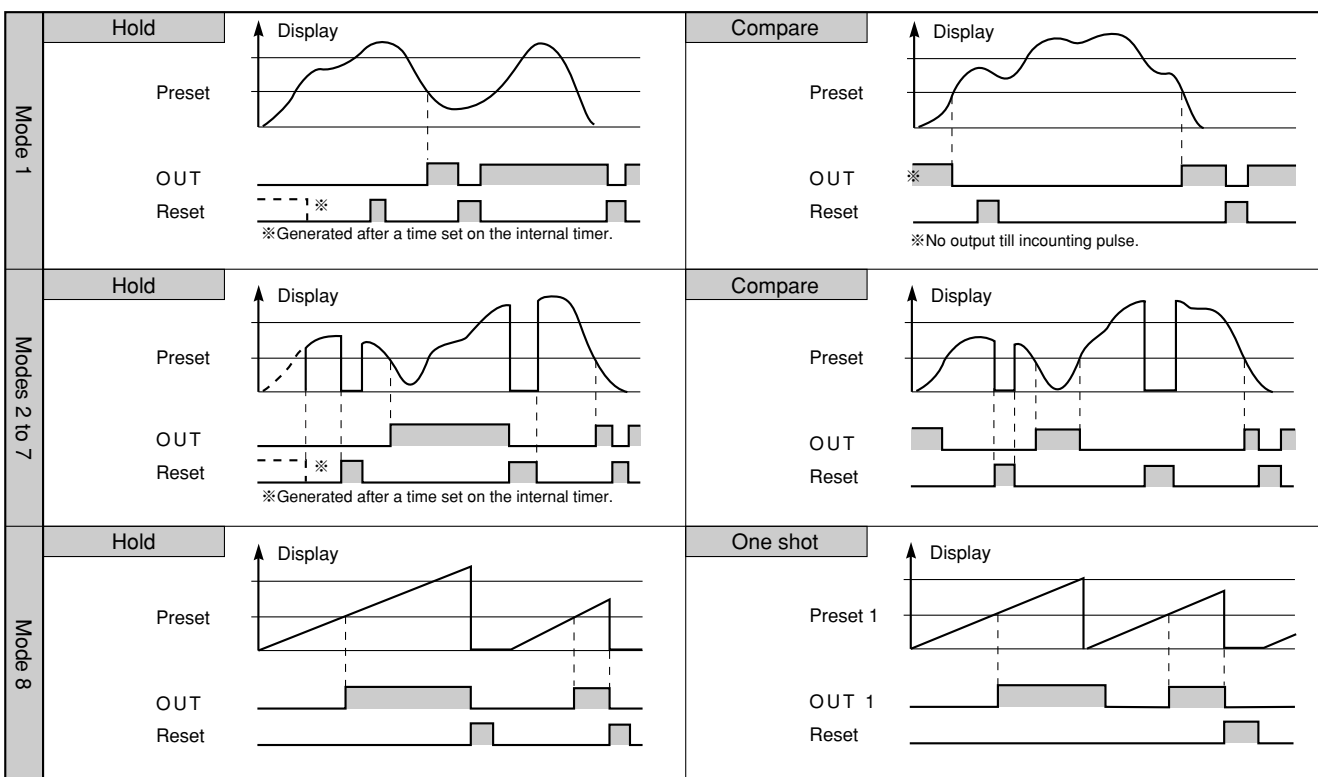

See page C-27 for the external dimension of the counter.

In the Compare mode, OUT is generated when the display value has reached the preset value .

TC series

Wiring

● Proximity sensor

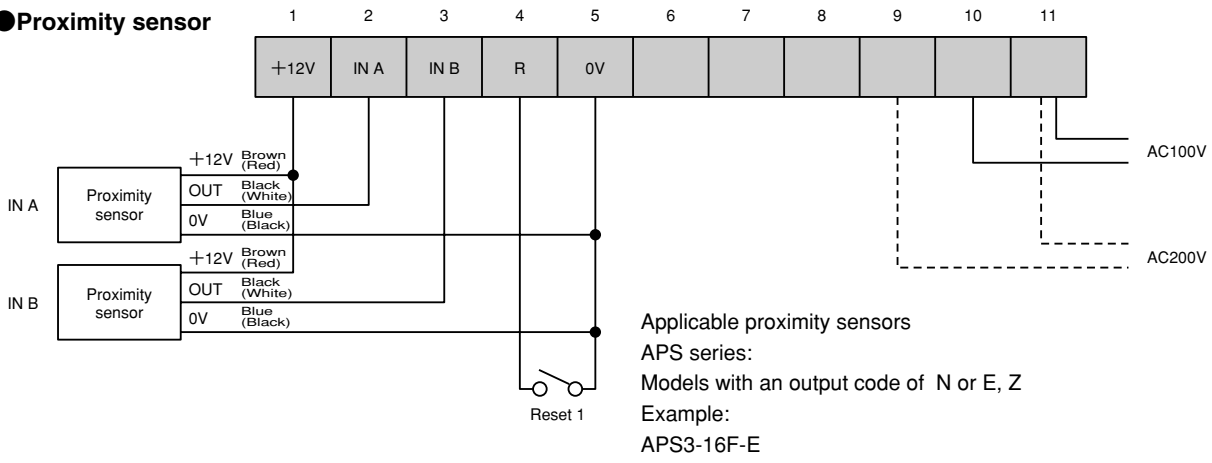

● Rotary encoder

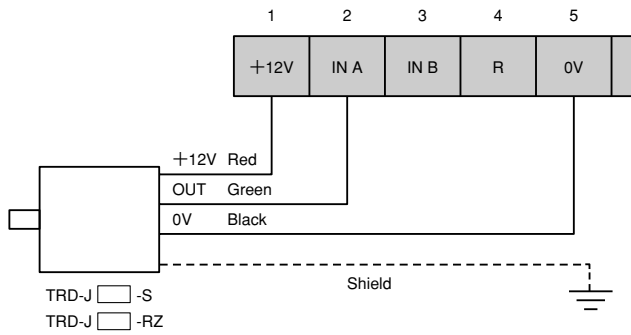

Digital
Tachometers

TC-V

TC-4L

TC-4I

TC-4C-4

TC-4B

TC-4S

Recommended application Measuring speed between two points

The tachometer can measure the speed of an moving object detected by two sensors. With the sensors positioned as shown below, the speed in meters per minute is calculated from their pulse counts and distance.

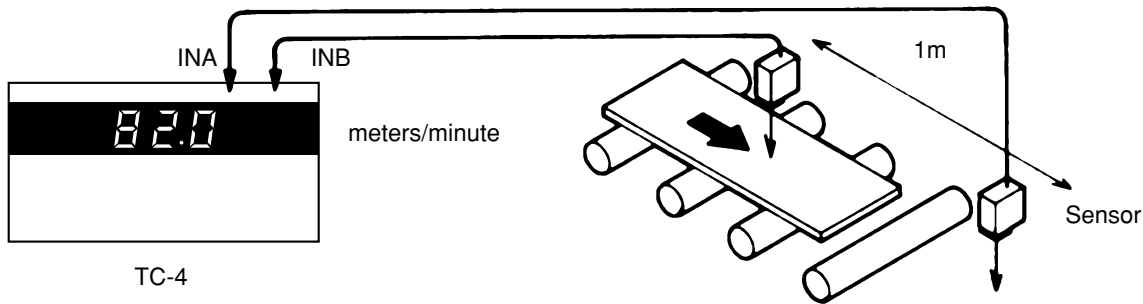

Step 1 Select the model.

Use TC-4 that displays speeds.

Step 2 Install sensors.

Use photoelectric sensors for inputs to INA and INB.

Step 3 Set the dip switches. On the rear panel, set the dip switches as follows:

| Switch | Set to | To select | Set |
|--------|--------------------|---------------------------------------|-----|
| 1 | Input frequency | Fast Input frequency | OFF |
| 2 | Decimal point | One digit after decimal point (000.0) | ON |
| 3 | | | OFF |
| 4 | Operation mode | Mode 2 | ON |
| 5 | | | OFF |
| 6 | | | OFF |
| 7 | Number of sampling | Times of sampling: 1 | OFF |
| 8 | | | OFF |

Step 4 Select a prescale

Select "1" by setting the rotary switches as follows (if the prescale has been changed from the initial value):

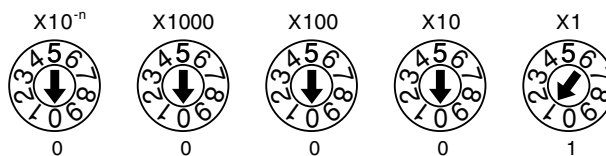

Step 5 Configure the circuit.

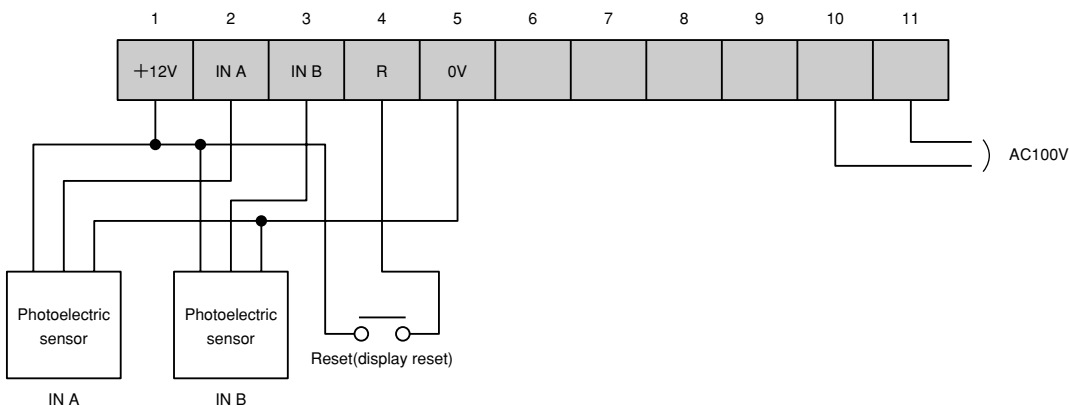

Digital Tachometers
TC-V
TC-4L
TC-41
TC-4C-4
TC-4B
TC-4S