

Characteristic specifications and options

Characteristic Specifications

Characteristic details	Applicable models							
	TRD-S/SH	TRD-2E	TRD-N/NH	TRD-J	TRD-GK	TRD-NA	TRD-K	TRD-KL
Longer or shorter cable	●	●	●	●	●	●	●	●
Modified cable ends (with connectors)	●	●	●	●	●	●	●	●
Non-standard pulse	●	●	●	●	●			
Longer shaft	●	●	●	●	●	●	●	●
Thicker or thinner shaft	●	●	●	●	●	●	●	●
Reverse rotation (The count increases in counterclockwise revolution.)							●	●

Options

● Bracket

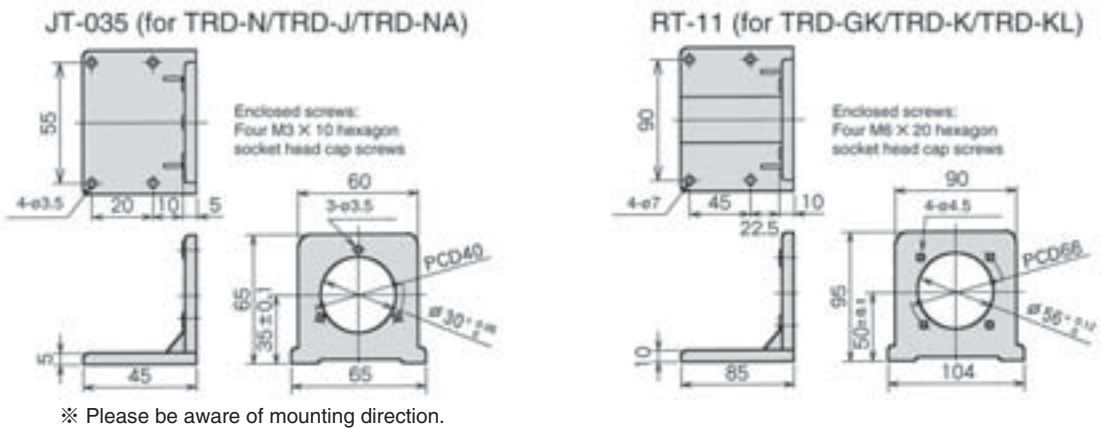

● Couplings

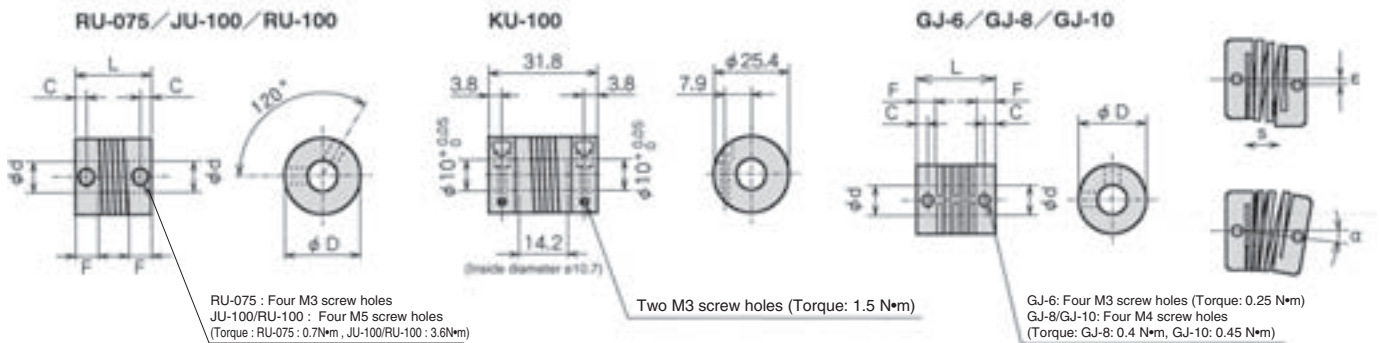

Type	Model	Applicable encoder	Material	d	D	L	F	C	α	ϵ	s
Metal coupling	RU-075	TRD-S/2E	Aluminum alloy (7075)	6 ^{+0.05}	19.1	19.1	4.8	2.4	5°MAX.	0.25mmMAX.	0.12mmMAX.
	JU-100	TRD-N/J/NA		8 ^{+0.05}	25.4	25.4	6.9	3.8	5°MAX.	0.25mmMAX.	0.12mmMAX.
	RU-100	TRD-GK/K/KL		10 ^{+0.05}	25.4	25.4	6.9	3.8	5°MAX.	0.25mmMAX.	0.12mmMAX.
	KU-100	TRD-GK/K/KL		-			5°MAX.	0.25mmMAX.	0.12mmMAX.		
Plastic coupling	GJ-6	TRD-S/2E	Glass fiber reinforced polyacetal	6 ^{+0.018}	15	21.6	5.2	2.8	6°MAX.	0.5mmMAX.	0.12mmMAX.
	GJ-8	TRD-N/J/NA		8 ^{+0.05}	19	24.0	6.8	3.5	5°MAX.	0.5mmMAX.	0.12mmMAX.
	GJ-10	TRD-GK/K/KL		10 ^{+0.05}	22	26.2	7.1	3.6	5°MAX.	0.5mmMAX.	0.12mmMAX.

● Cable connector (for TRD-GK/TRD-K/TRD-KL Series)

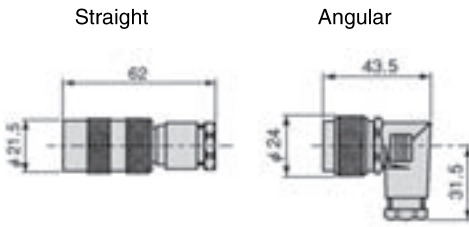

Type	For TRD-GK Series		For TRD-K/TRD-KL Series	
	Straight	Angular	Straight	Angular
Model number	BMCC-6	BAFC-6	BMCC-12	BAFC-12
Number of pins	6P		12P	
Section area	0.75 mm ² max.		0.25 mm ² max.	
Terminal	Soldered			
External diameter of cable	5 to 8 mm			
Protection	IP67 (connected and locked)			

● Relay cables

Applicable absolute encoders	Appearance	Cable length	Model number	Remarks	
<p>TRD-NA360NWE TRD-NA720NWE</p>		3 m	F-30GF	For FC-80-C/160/320 and FC-81F-C/161F-C/321F-C programmable cam	
		5 m	F-50GF		
		10 m	F-100GF		
		2 m	F-20G		Extension cable
3 m	F-30G				
5 m	F-50G				
10 m	F-100G				
<p>TRD-K</p> <p>TRD-K360-YC2 TRD-KL360-YC2</p> <p>TRD-K720-YC2 TRD-KL720-YC2</p>		2 m	F-20ANC2	For FC-80-C/160/320 and FC-81F-C/161F-C/321F-C programmable cam	
		5 m	F-50ANC2		
		2 m	F-20BNC2		
		5 m	F-50BNC2		
		2 m	F-20ANC2A		
		5 m	F-50ANC2A		
		2 m	F-20BNC2A		
		5 m	F-50BNC2A		
<p>TRD-KL</p> <p>TRD-K360-YC2 TRD-K512-YC2</p> <p>TRD-K720-YC2 TRD-K1024-YC2</p> <p>TRD-KL360-YC2 TRD-KL512-YC2</p> <p>TRD-KL720-YC2 TRD-KL1024-YC2</p>		2 m	F-20C2	For FC-21 programmable cam	
		2 m	F-20C2A		
		5 m	F-50J		Extension cable
		15 m	F-150J		

● FC-21 connector

Model: Made by Honda MR-16L/MR-16M

● Extension cable connector

Model: Made by Hirose RM15TPD-12P

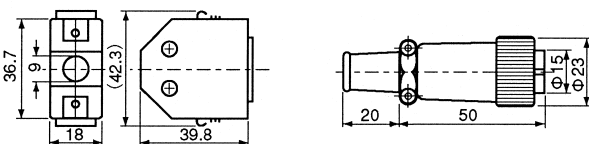

See page 29 for pin alignment.

● KOYO Programmable Cam

(electronic cam)

Used with absolute rotary encoders, the programmable cam precisely position processing machines. Applicable processes include assembling, printing, pressing and packaging. A wide variety of models are available to suit your needs.

