

Resin Cylindrical Type APS-GK Series

Multi-purpose Economical Type with Proven Performance.

DC 2-wire/3-wire and AC 2-wire Types Are Available.

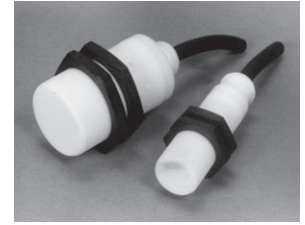

Types

DC 2-wire type

Shape	Operating distance (mm)	Output type	Model number	Remarks
M12 Non-embedded type	5	N.O.	APS5-12GK-Z	
M18 Embedded type	5	N.O.	APS5-18GK-Z-TF	Fluoroplastic type
M18 Non-embedded type	10	N.O.	APS10-18GK-Z	
M30 Embedded type	10	N.O.	APS10-30GK-Z-TF	Fluoroplastic type
M30 Non-embedded type	18	N.O.	APS18-30GK-Z	

DC 3-wire type

Shape	Operating distance (mm)	Output type	Model number	Remarks
M12 Non-embedded type	5	NPN N.O.	APS5-12GK-E	Frequency classification model available ("L" or "H" is added in the end of model number).
		PNP N.O.	APS5-12GK-E2	
M18 Non-embedded type	10	NPN N.O.	APS10-18GK-E	Frequency classification model available ("L" is added in the end of model number).
		PNP N.O.	APS10-18GK-E2	
M30 Non-embedded type	18	NPN N.O.	APS18-30GK-E	

* Frequency classification models (H/L) are non-stock product.

AC 2-wire type

Shape	Operating distance (mm)	Output type	Model number	Remarks
M18 Non-embedded type	10	N.O.	APS10-18GK-WS	
M30 Embedded type	10	N.O.	APS10-30GK-WS-TF	Fluoroplastic type
M30 Non-embedded type	18	N.O.	APS18-30GK-WS	

DC 2-wire, Embedded Type

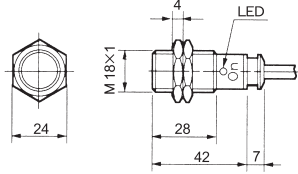
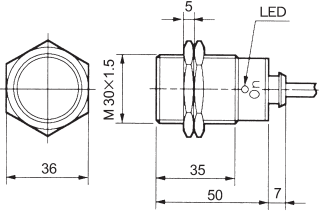
Effective operating distance	5 mm ±10%	10 mm ±10%		
Dimensions (mm)				
Remarks	Fluoroplastic type Operation indicator LED feature	Fluoroplastic type Operation indicator LED feature		
Output type	NO	Model number	APS5-18GK-Z-TF	APS10-30GK-Z-TF
		Price	¥10,000	¥11,000
Rated operating voltage	DC+12/+24 V (+10 to +36 V) Permissible ripple rate: 10%p-p or less (max peak voltage: 36 V or less)			
Standard target object (mm)	Iron 18 × 18 × 1t		Iron 30 × 30 × 1t	
Rated operating distance	0 to 4mm		0 to 8mm	
Responding material	Iron/nonferrous metal (operating distance varies with material)			
Differential travel	Approx. 20% or less			
Switching frequency	500 Hz		300 Hz	
Rated operating current	5 to 200 mA			
Voltage drop	3 V or less (when the cable length is 2 m)			
Leakage current	1.0 mA or less (0.8 mA TYP)			
Indicator lamp	Operation indication			
Operating temperature	-25 to +70 °C			
Temperature characteristics	Within ±10% (of operating distance at +20 °C)			
Withstand voltage	1000 VAC, 50/60 Hz (1 minute)			
Insulation resistance	50 MΩ or higher (500 VDC)			
Vibration resistance	Double amplitude: 1.5 mm, 10 to 55 Hz (2 hours in each of X, Y and Z directions)			
Impact resistance	1000 m/s ² , within 11 ms (10 cycles in each of X, Y and Z directions)			
Protection grade	IP67			
Casing material	Fluoroplastic (Nut: PPS resin)			
Lead wire	Oil-resistant vinyl chloride cable 2 m Outer diameter (approx. ø6), 0.5 mm ² 2-wire			
Tightening torque	2 Nm or less		3 Nm or less	
Weight	Approx. 90 g		Approx. 130 g	

APS-GMC

APS-GMD

APS-GM

APS-GK

APS-30/31

APS-CK

APS-S/M

APS-F/U

APS-10~15

APS-CU

CS

Resin Cylindrical Type APS-GK Series

DC 2-wire, Non-embedded Type

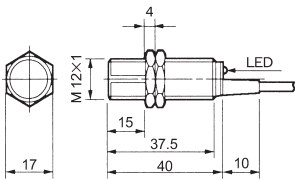
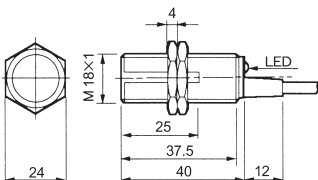
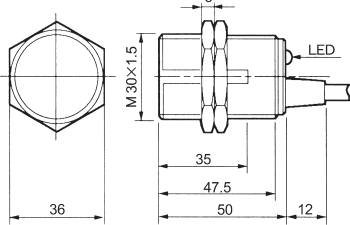
Effective operating distance		5 mm ±10%	10 mm ±10%	18 mm ±10%	
Dimensions (mm)					
Remarks		Operation indicator LED feature	Operation indicator LED feature	Operation indicator LED feature	
Output type	NO	Model number	APS5-12GK-Z	APS10-18GK-Z	APS18-30GK-Z
		Price	¥5,000	¥5,600	¥6,200
Rated operating voltage		DC+12/+24 V (+10 to +36 V) Permissible ripple rate: 10%p-p or less (max peak voltage: 36 V or less)			
Standard target object (mm)		Iron 15 × 15 × 1t	Iron 30 × 30 × 1t	Iron 54 × 54 × 1t	
Rated operating distance		0 to 4 mm	0 to 8 mm	0 to 14.5 mm	
Responding material		Iron/nonferrous metal (operating distance varies with material)			
Differential travel		Approx. 20% or less			
Switching frequency		400 Hz	200 Hz	100 Hz	
Rated operating current		5 to 200 mA			
Voltage drop		3 V or less (when the cable length is 1 m)			
Leakage current		1.0 mA or less (0.8 mA TYP)			
Indicator lamp		Operation indication			
Operating temperature		-25 to +70 °C			
Temperature characteristics		Within ±10% (of operating distance at +20 °C)			
Withstand voltage		1000 VAC, 50/60 Hz (1 minute)			
Insulation resistance		50 MΩ or higher (500 VDC)			
Vibration resistance		Double amplitude: 1.5 mm, 10 to 55 Hz (2 hours in each of X, Y and Z directions)			
Impact resistance		500m/s ²	1000m/s ²		
		Within 11 ms (10 cycles in each of X, Y and Z directions)			
Protection grade		IP67			
Casing material		PBT resin			
Lead wire		Oil-resistant vinyl chloride cable 1 m Outer diameter (approx. ø3.5), 0.14 mm ² 2-wire	Oil-resistant vinyl chloride cable 1 m Outer diameter (approx. ø6), 0.5 mm ² 2-wire		
Tightening torque		1 Nm or less	2 Nm or less	3 Nm or less	
Weight		Approx. 30 g	Approx. 70 g	Approx. 100 g	

DC 3-wire, Non-embedded Type

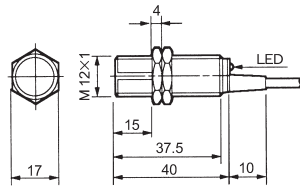
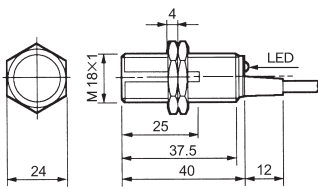
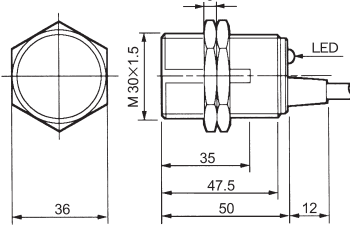
Effective operating distance		5 mm ±10%	10 mm ±10%	18 mm ±10%	
Dimensions (mm)					
Remarks		Frequency classification model available Operation indicator LED feature	Frequency classification model available Operation indicator LED feature	Operation indicator LED feature	
Output type	NPN NO	Model number	APS5-12GK-E	APS10-18GK-E	APS18-30GK-E
		Price	¥3,400	¥3,800	¥4,200
	PNP NO	Model number	APS5-12GK-E2	APS10-18GK-E2	
		Price	¥3,400	¥3,800	
Rated operating voltage		DC+12/+24 V (+10 to +36 V) Permissible ripple rate: 3%p-p or less			
No-load current		20 mA or less			
Standard target object (mm)		Iron 15 × 15 × 1t	Iron 30 × 30 × 1t	Iron 54 × 54 × 1t	
Rated operating distance		0 to 4 mm	0 to 8 mm	0 to 14.5 mm	
Responding material		Iron/nonferrous metal (operating distance varies with material)			
Differential travel		Approx. 20% or less			
Switching frequency		400 Hz	200 Hz	100 Hz	
Rated operating current		100 mA max (12 VDC) / 200 mA max (24 VDC)			
Voltage drop		1.5 V or less (1.0 V TYP)			
Leakage current		100 μA or less			
Indicator lamp		Operation indication			
Operating temperature		-25 to +70°C			
Temperature characteristics		Within ±10% (of operating distance at +20°C)			
Withstand voltage		500 VAC, 50/60 Hz (1 minute)			
Insulation resistance		50 MΩ or higher (500 VDC)			
Vibration resistance		Double amplitude: 1.5 mm, 10 to 55 Hz (2 hours in each of X, Y and Z directions)			
Impact resistance		600 m/s ² , within 11 ms (10 cycles in each of X, Y and Z directions)			
Protection grade		IP67			
Casing material		PBT resin			
Lead wire		Oil-resistant vinyl chloride cable 1 m Outer diameter (approx. ø3.5), 0.11 mm ² 3-wire	Oil-resistant vinyl chloride cable 1 m Outer diameter (approx. ø6), 0.5 mm ² 3-wire		
Tightening torque		1 Nm or less	2 Nm or less	3 Nm or less	
Weight		Approx. 30 g	Approx. 70 g	Approx. 110 g	

The frequency classification models have "L" or "H" at the end of its model number (non-stock product).

APS-GMC

APS-GMD

APS-GM

APS-GK

APS-30/31

APS-CK

APS-S/M

APS-F/U

APS-10~15

APS-CU

CS

Resin Cylindrical Type APS-GK Series

DC 2-wire, Non-embedded Type/Embedded Type

Effective operating distance		10 mm ±10%	18 mm ±10%	10 mm ±10%
Dimensions (mm)		<p>Non-embedded type</p>	<p>Non-embedded type</p>	<p>Embedded type</p>
Remarks		Operation indicator LED feature	Operation indicator LED feature	Fluoroplastic type Operation indicator LED feature
Output type	NO	Model number APS10-18GK-WS	APS18-30GK-WS	APS10-30GK-WS-TF
		Price ¥6,500	¥7,600	¥14,000
Rated operating voltage		AC24 to 240 V(AC20 to 264 V) 50/60 Hz		
Standard target object (mm)		Iron 30 × 30 × 1t	Iron 54 × 54 × 1t	Iron 30 × 30 × 1t
Rated operating distance		0 to 8 mm	0 to 14.5 mm	0 to 8 mm
Responding material		Iron/nonferrous metal (operating distance varies with material)		
Differential travel		Approx. 20% or less		
Switching frequency		25 Hz		
Rated operating current		5 to 200 mA		
Voltage drop		(See the "Voltage Drop Characteristics" diagram)		
Leakage current		1.5 mA or less (1.0 mA TYP)		
Indicator lamp		Operation indication		
Operating temperature		-25 to +70°C		
Temperature characteristics		Within ±10% (of operating distance at +20°C)		
Withstand voltage		2500 VAC, 50/60 Hz (1 minute)		
Insulation resistance		50 MΩ or higher (500 VDC)		
Vibration resistance		Double amplitude: 1.5 mm, 10 to 55 Hz (2 hours in each of X, Y and Z directions)		
Impact resistance		1000 m/s ² , within 11 ms (10 cycles in each of X, Y and Z directions)		
Protection grade		IP67		
Casing material		PBT resin		Fluoroplastic (nut: PPS resin)
Lead wire		Oil-resistant vinyl chloride cable 1 m Outer diameter (approx. ø6), 0.5 mm ² 2-wire		Oil-resistant vinyl chloride cable 2 m Outer diameter (approx. ø6), 0.5 mm ² 2-wire
Tightening torque		2 Nm or less	3 Nm or less	3 Nm or less
Weight		Approx. 70 g	Approx. 110 g	Approx. 170 g

APS-GMC

APS-GMD

APS-GM

APS-GK

APS-30/31

APS-CK

APS-S/M

APS-F/U

APS-10~15

APS-CU

CS

Connection/Operation

(Target object Not present Present)

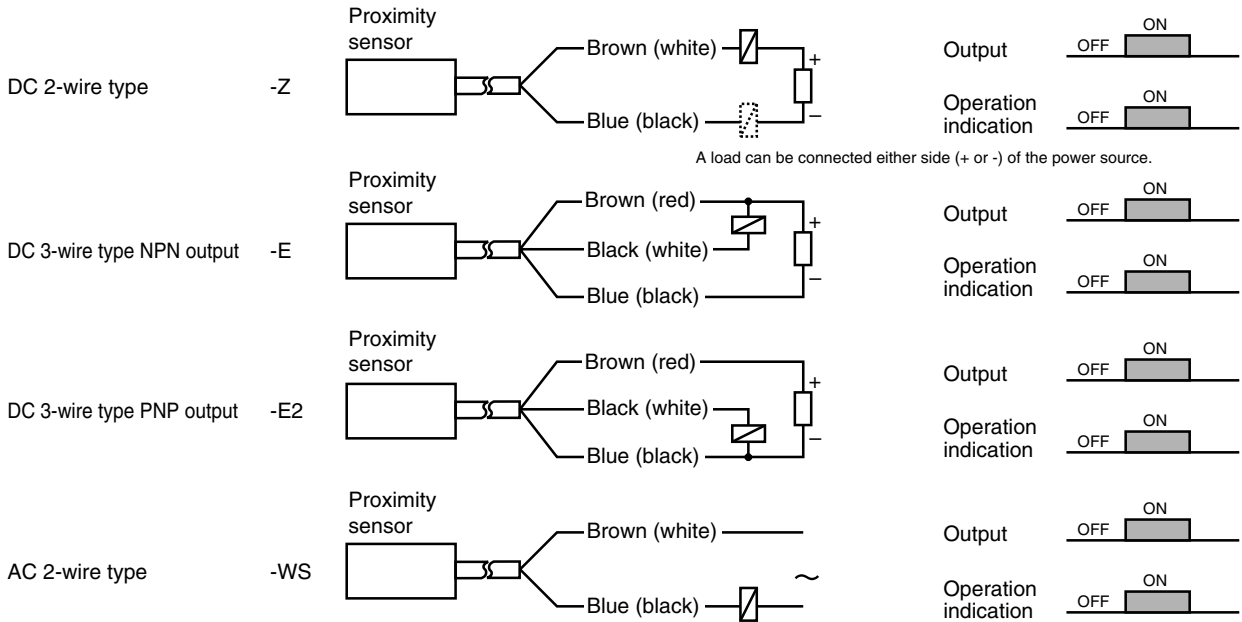

Note: indicates a load. Operation indication is only available for models having LED.

Characteristics Diagrams

AC 2-wire type -WS

● Voltage Drop Characteristics (Representative Examples)

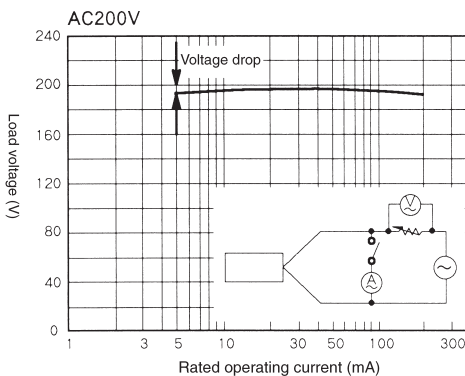
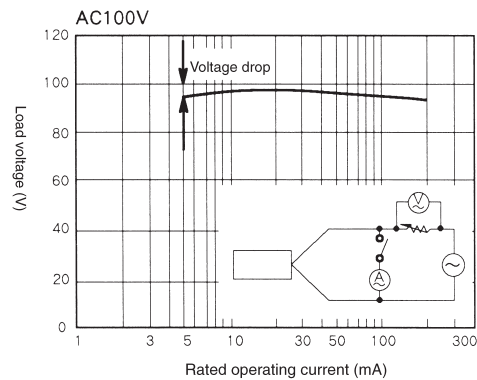
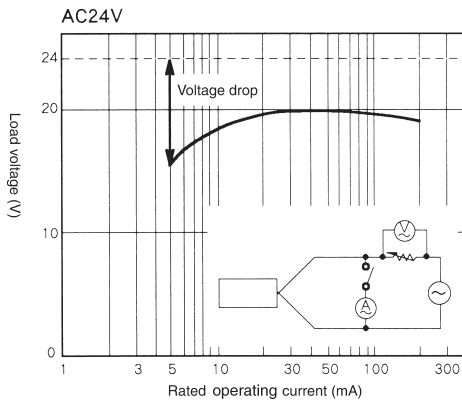

APS-GMC

APS-GMD

APS-GM

APS-GK

APS-30/31

APS-CK

APS-S/M

APS-F/U

APS-10~15

APS-CU

CS

Installation and Influence of Surrounding Metals

A proximity sensor is susceptible to surrounding metals. When installing the sensor, secure a sufficient distance longer than the indicated dimension.

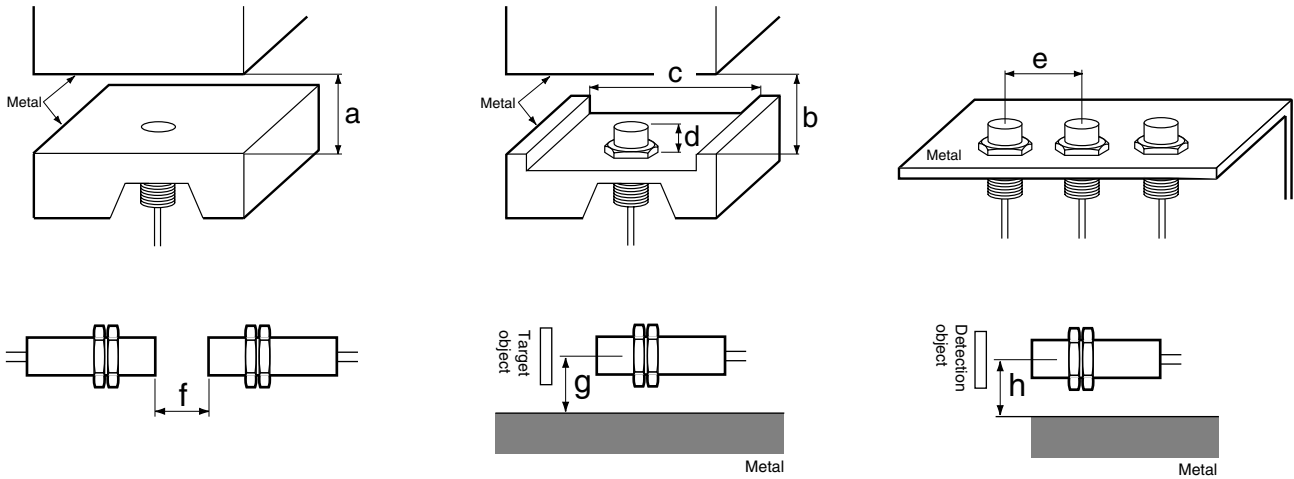

(in mm)

Model number	a	b	c	d	e	f	g	h
APS5-12GK...	-	20	40	15	80	100	20	15
APS10-18GK...	-	40	70	25	110	150	35	30
APS18-30GK...	-	70	100	35	170	200	50	45
APS5-18GK...	20	-	-	-	36	50	12	9
APS10-30GK...	40	-	-	-	60	100	20	15

Mutual Interference and Model Classification by Frequency

(in mm)

When using two or more proximity sensors in close contact with each other, secure an interval between the proximity sensors (center to center) at least 10 times the operating distance. If the interval is inadequate, mutual interference may occur.

In applications where it is impossible to secure adequate intervals, use models classified by frequency. Normally, frequency classification is indicated by an alphabet immediately after the operating distance of the model number.

● Those models classified by frequency have either of the following markings on the cable so that they can easily be distinguished from other models.

For high frequencies (H) : yellow spiral mark

For low frequencies (L) : red spiral mark

Example:

APS5- 12GK-E(M) Model with a standard frequency (normally, "M" is omitted)

APS5- 12GK-EL Model with a lower frequency than the standard frequency

APS5- 12GK-EH Model with a higher frequency than the standard frequency

Combinations of models classified by frequency (can be installed with casings in close contact with each other)

APS5-12GK-E(M)LH	<p>L (M) H</p> <p>* To install four or more sensors in close contact, preliminary study is required.</p>
APS10-18GK-E(M)L	<p>(M) L</p> <p>50</p>

Detection Area Diagrams (Representative Examples)

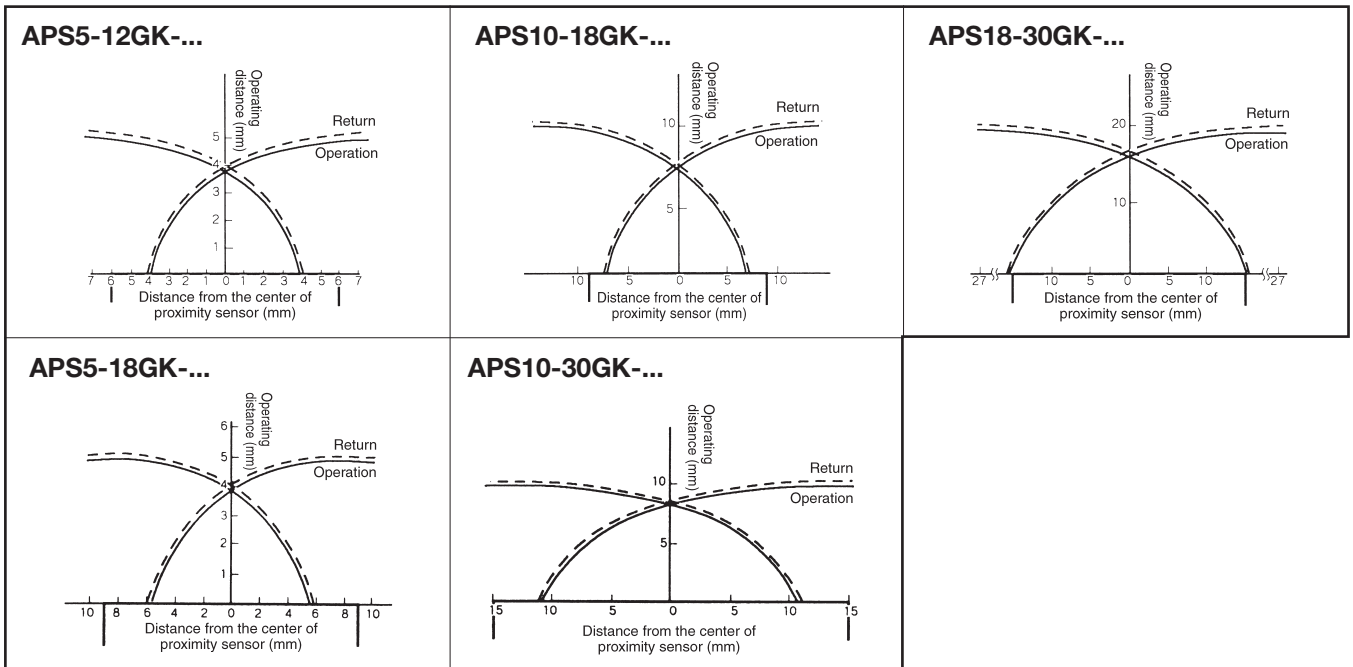

Shape Characteristics (Representative Examples)

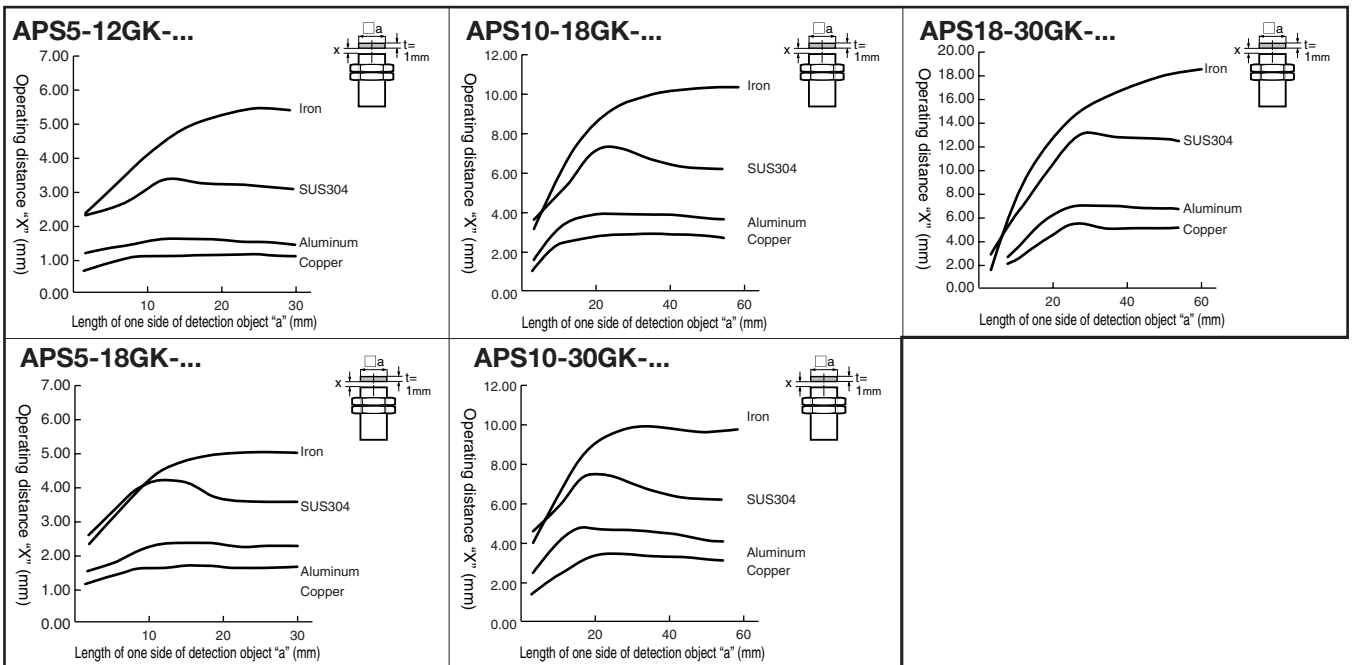

APS-GMC

APS-GMD

APS-GM

APS-GK

APS-30/31

APS-CK

APS-S/M

APS-F/U

APS-10~15

APS-CU

CS