

# Capacitive Type CS Series

Capable of detecting not only metals but also any type of material, including wood, paper and plastics.



## Features

- Available in resin cylindrical, metal cylindrical and square shapes.

## Types

DC voltage output type/DC 3-wire type

Shape		Operating distance (mm)		Output type	Model number
Resin cylindrical M22	Non-embedded type	5		DC voltage	CS-31-5T *
				NPN N.O.	CS-31-5N *
Metal cylindrical M30	Non-embedded type	15		DC voltage	CS-85-15T
				NPN N.O.	CS-85-15N
Rectangular type	Non-embedded type	5		DC voltage	CS-16-5T
				NPN N.O.	CS-16-5N
		10		NPN N.O.	CS10-34CU-E

\* When installing the sensor, use the dedicated resin nut provided.

APS-GMC

APS-GMD

APS-GM

APS-GK

APS-30/31

APS-CK

APS-S/M

APS-F/U

APS-10~15

APS-CU

CS

DC Voltage Output Type/DC 3-wire, Non-embedded Type

Effective operating distance	5 mm ±10%	15 mm ±10%		
Dimensions (mm)				
Remarks	Resin cylindrical type	Metal cylindrical type		
Output type	DC voltage	Model number	<b>CS-31-5T*</b>	<b>CS-85-15T</b>
		Price	¥6,900	¥8,100
	NPN NO	Model number	<b>CS-31-5N*</b>	<b>CS-85-15N</b>
		Price	¥6,900	¥8,100
Rated operating voltage	Voltage output type (T type)	DC+12 V (+10 to +16 V) Permissible ripple rate: 10%p-p or less		
	DC switching type (N type)	DC+24 V (+20 to +30 V) Full-wave rectified operating voltage available (+20 to +30 V average)	DC+12/24 V (+20 to +30 V) Full-wave rectified operating voltage available (+10 to +30 V average)	
No-load current	T type: 27 mA or less N type: 20 mA or less			
Standard target object (mm)	Iron 50 × 50 × 1t (grounded)			
Responding material	Iron/nonferrous metal (operating distance varies with material)			
Effective operating distance	Operating distance is adjustable with multi-turn volume.			
Differential travel	Approx. 20%			
Switching frequency	50 Hz			
Output	T type	Output impedance: 1.8 kΩ (output standard: 8P6N)		
	N type <small>Rated operating current</small>	100 mA max (load voltage: 50 V or less)		
Voltage drop (N type)	2.0 V or less			
Leakage current (N type)	200 μA or less			
Indicator lamp	Operation indication			
Operating temperature	-25 to +70°C			
Temperature characteristics	Within ±20% (of operating distance at +20°C)			
Withstand voltage	500 VAC, 50/60 Hz (1 minute)			
Insulation resistance	5 MΩ or higher (500 VDC)			
Vibration resistance	Double amplitude: 1.5 mm, 10 to 55 Hz (2 hours in each of X, Y and Z directions)			
Impact resistance	600 m/s <sup>2</sup> , within 11 ms (10 cycles in each of X, Y and Z directions)			
Protection grade	IP65			
Casing material	Polycarbonate	Brass nickel plated (detection plane: polycarbonate)		
Lead wire	Oil-resistant vinyl chloride cable 1.5 m Outer diameter (approx. ø4.5), 0.3 mm <sup>2</sup> 3-wire	Oil-resistant vinyl chloride cable 2 m Outer diameter (approx. ø6), 0.5 mm <sup>2</sup> 3-wire		
Tightening torque	3 Nm or less	20 Nm or less		
Weight	Approx. 80 g	Approx. 250 g		

\* When installing **CS-31-5T** or **CS-31-5N**, use the dedicated resin nut provided.

APS-GMC  
APS-GMD  
APS-GM  
APS-GK  
APS-30/31  
APS-CK  
APS-S/M  
APS-F/U  
APS-10~15  
APS-CU  
CS

# Capacitive Type CS Series

## DC Voltage Output Type/DC 3-wire, Non-embedded Type

Effective operating distance		10 mm ±10%	5 mm ±10%
Dimensions (mm)			
Remarks		Rectangular type	Rectangular type
Output type	DC voltage	Model number	<b>CS-16-5T</b>
		Price	¥4,800
NPN NO		Model number	<b>CS10-34CU-E</b>
		Price	¥3,100
Rated operating voltage		DC+12/24 V (+20 to +30 V) Permissible ripple rate: 3%p-p or less	T type: DC+12 V (+10 to +16 V) Permissible ripple rate: 10%p-p or less N type: DC+12/24 V (+20 to +30 V) Full-wave rectified operating voltage available (+10 to +30 V average)
No-load current		20 mA or less	T type: 27 mA or less N type: 20 mA or less
Standard target object (mm)		Iron 50 × 50 × 1t (grounded)	
Responding material		Iron/nonferrous metal (operating distance varies with material)	
Effective operating distance		10 mm ±10%	Operating distance is adjustable with multi-turn volume.
Differential travel		Approx. 20% or less	Approx. 20%
Switching frequency		10 Hz max	50 Hz
Output	T type	Output impedance: 1.8 kΩ (output standard: 8P6N)	
	N/E type <small>Rated operating current</small>	E type: 100 mA max	N type: 100 mA (load voltage: 50 V or less)
Voltage drop		2.0 V or less (except <b>CS-16-5T</b> )	
Leakage current		200 μA or less (except <b>CS-16-5T</b> )	
Indicator lamp		Operation indication	
Operating temperature		-10 to +55°C	
Temperature characteristics		Within ±15% (of operating distance at +23°C)	Within ±20% (of operating distance at +20°C)
Withstand voltage		500 VAC, 50/60 Hz (1 minute)	
Insulation resistance		50 MΩ or higher (500 VDC)	5 MΩ or higher (500 VDC)
Vibration resistance		Double amplitude: 1.5 mm, 10 to 55 Hz (2 hours in each of X, Y and Z directions)	
Impact resistance		490 m/s <sup>2</sup>	600m/s <sup>2</sup>
		Within 11 ms (10 cycles in each of X, Y and Z directions)	
Protection grade		IP66	IP50 (dust resistant)
Casing material		PBT	Aluminum (detection plane: polycarbonate)
Lead wire		Oil-resistant vinyl chloride cable 2.0 mm Outer diameter (approx. ø3.8), 0.3 mm <sup>2</sup> 3-wire	Oil-resistant vinyl chloride cable 1.5 mm Outer diameter (approx. ø4), 0.3 mm <sup>2</sup> 3-wire
Tightening torque		0.4 Nm or less	0.8 Nm or less
Weight		Approx. 80 g	Approx. 100 g

## Connection/Operation

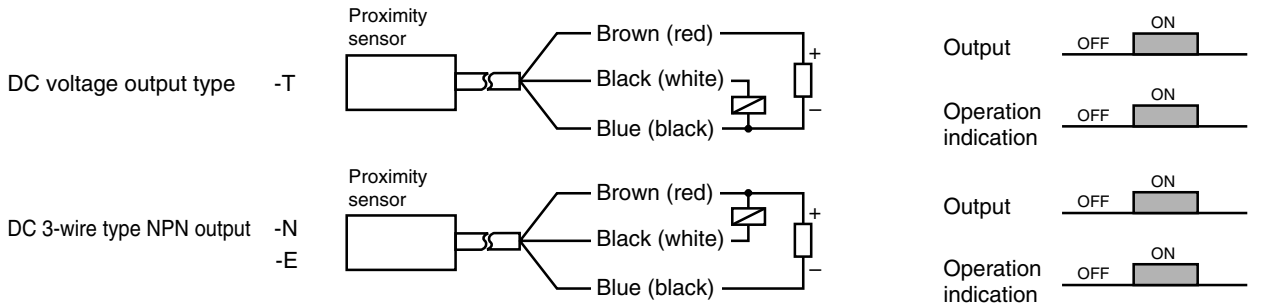

Note: indicates a load.

## Installation Method

A capacitive proximity sensor detects an object by sensing change in capacitance of the surrounding bodies. When installing the sensor, secure a distance between the sensor and the surrounding bodies longer than the corresponding value indicated in the table below.

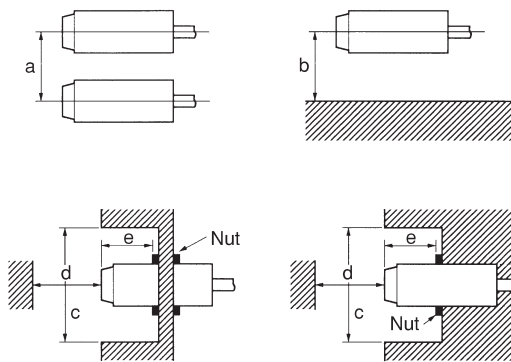

	a	b	c	d	e
CS-31	44	33	66	44	22
CS-85	60	45	90	60	30
CS-16	92	69	138	92	46
CS10-34CU	40	30	60	30	10.4

A capacitive proximity sensor is highly sensitive to water. Do not use a capacitive proximity sensor in high humidity or in locations where the sensor is likely to be contacted directly with water. Doing so may cause malfunction.

When using the sensor in locations where it is likely to be contacted directly with water droplets or the like, it is necessary to take a preventive measure such as one indicated below.

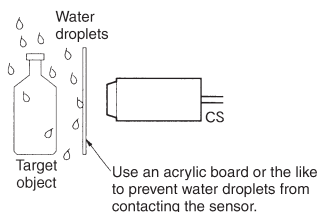

## Grounding

The operating distance varies according to the grounding state of the standard target object (50 × 50 × 1 t) and that of the capacitive proximity sensor. Take this into account when installing the sensor and determining the responding material.

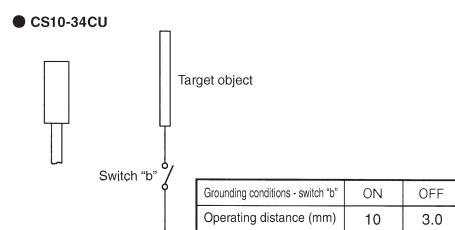
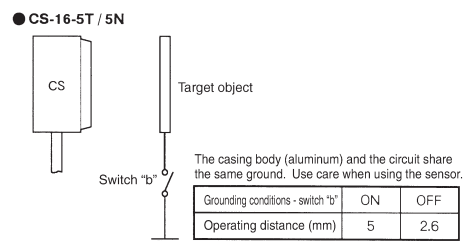
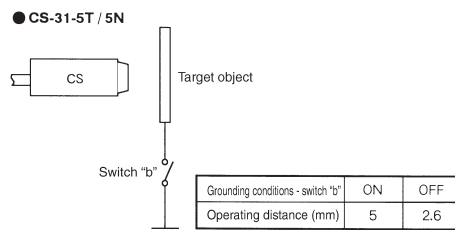
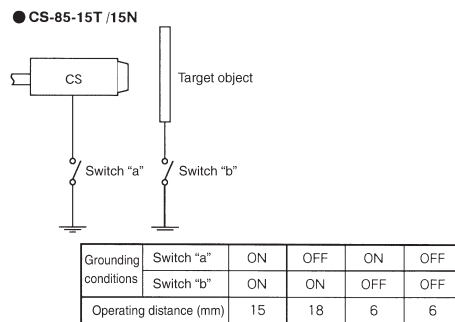

APS-GMC

APS-GMD

APS-GM

APS-GK

APS-30/31

APS-CK

APS-S/M

APS-F/U

APS-10~15

APS-CU

CS

APS-GMC  
 APS-GMD  
 APS-GM  
 APS-GK  
 APS-30/31  
 APS-CK  
 APS-S/M  
 APS-F/U  
 APS-10~15  
 APS-CU  
 CS

## Potentiometer for Adjusting the Operating Distance

A capacitive proximity sensor is equipped with a multi-turn potentiometer in the back for adjusting the operating distance. After installing the capacitive proximity sensor, turn this multi-turn potentiometer to adjust the operating distance to the standard distance while using a metal plate equal to or greater than the grounded standard target object (50 × 50 × 1 t), or shorter than the standard distance depending on the application. Turning the potentiometer to the right increases the operating distance, while turning it left decreases the distance. The maximum number of turns for adjustment is 16 ± 5. However, even if the maximum number is exceeded, the rotation continues without damaging the potentiometer. Setting the operating distance greater than the rated operating distance will make the operation unstable. (CS10-34CU-E is excluded.)

## Precautions

- (1) Use much care not to cause condensation or freezing on the detection plane, or let dust adhere to the detection plane. They may cause malfunction.
- (2) Use care not to let a liquid or powder in a non-metallic container adhere to the sensor. It may cause malfunction.

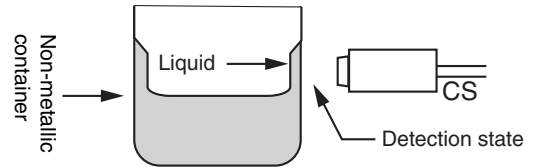

- (3) To install CS-16-5T or CS-16-5N, use M4 screws. When installing these models, use care not to let the screws enter the casing by more than 6 mm.
- (4) With a DC 3-wire type proximity sensor, a load with a large making current (lamp, motor, solenoid or the like with a making current of 200 mA or higher) may deteriorate or damage the switching element. In such a case, insert a relay between the sensor and the load.

## Characteristics of Material

Even when detecting the same material, the operating distance varies depending on the object size, shape and other factors. The following table shows examples of different operating distances with different materials and different shapes in detection with a capacitive proximity sensor (operating distance varies with electric characteristics, such as conductivity and specific inductive capacity, as well as water absorption and volume).

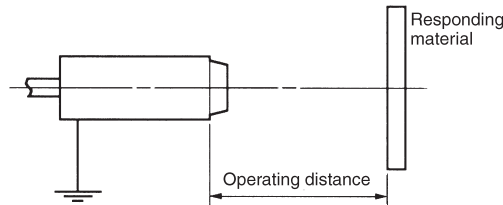

● When assuming the operating distance with iron to be 100%:

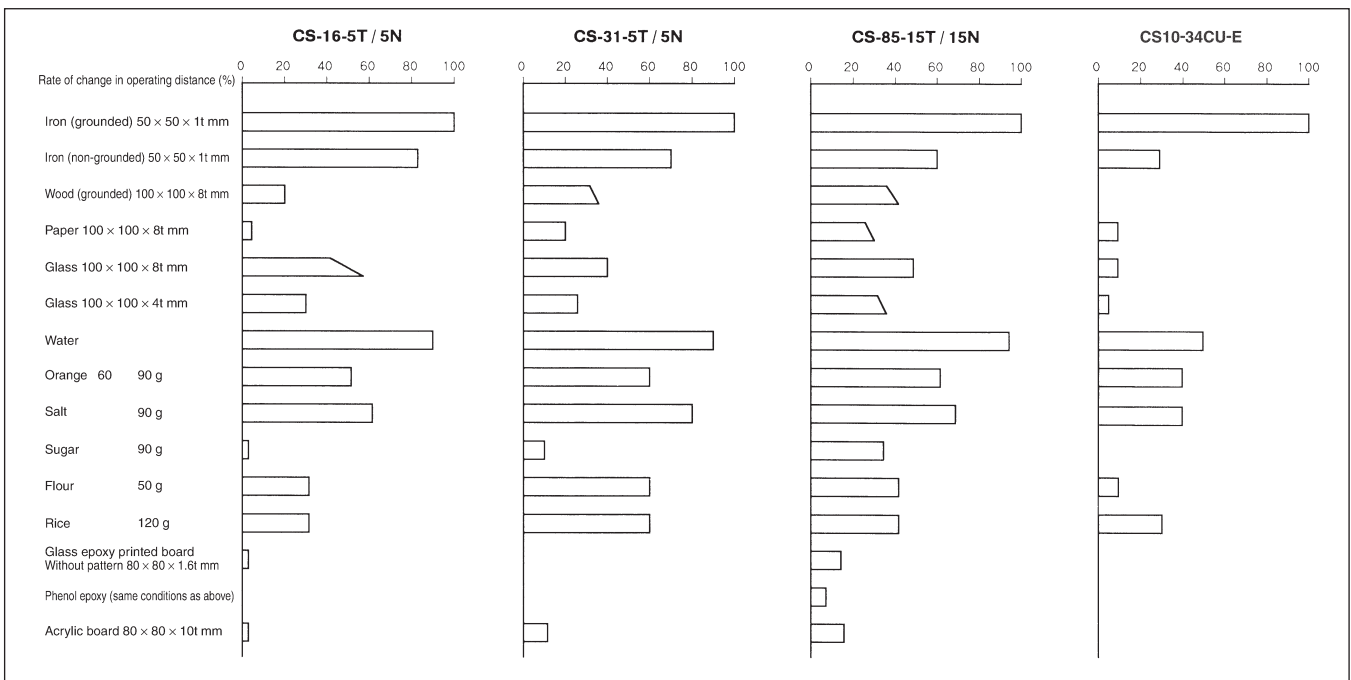

## Characteristics of Aluminum Material by Thickness

The operating distance varies with the thickness of the target object. The figure below shows the operating distance when a target object with the same size as the standard target object and a different thickness is used.

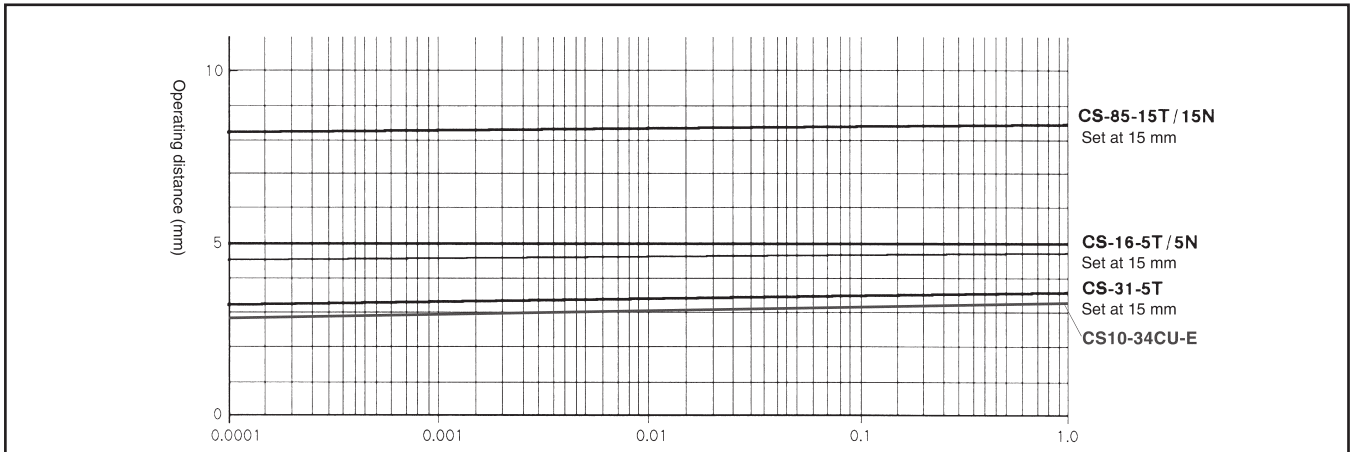

## Detection Area Drawings (Representative Examples)

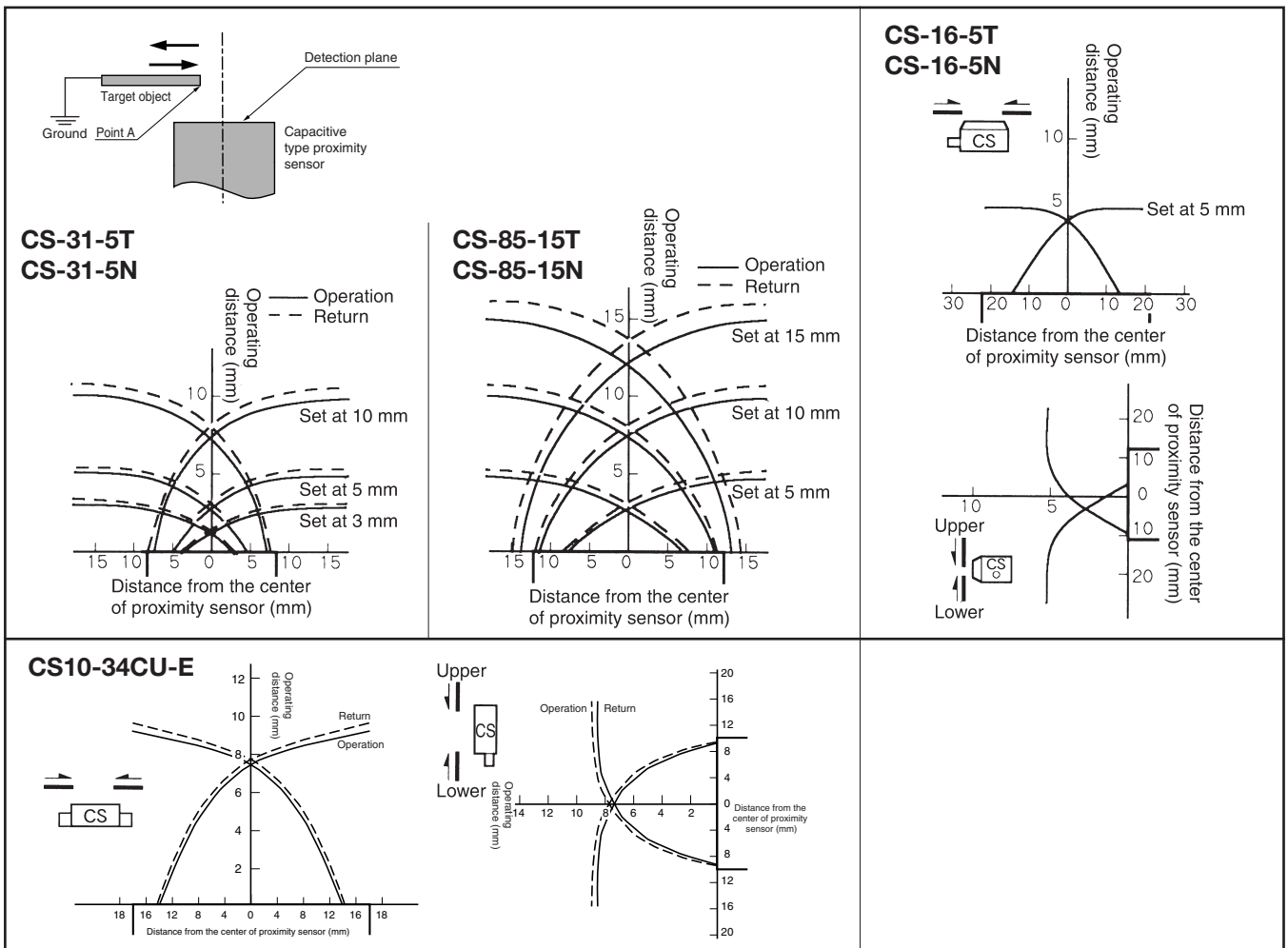

APS-GMC  
 APS-GMD  
 APS-GM  
 APS-GK  
 APS-30/31  
 APS-CK  
 APS-S/M  
 APS-F/U  
 APS-10~15  
 APS-CU  
 CS

Shape Characteristics (Representative Examples)

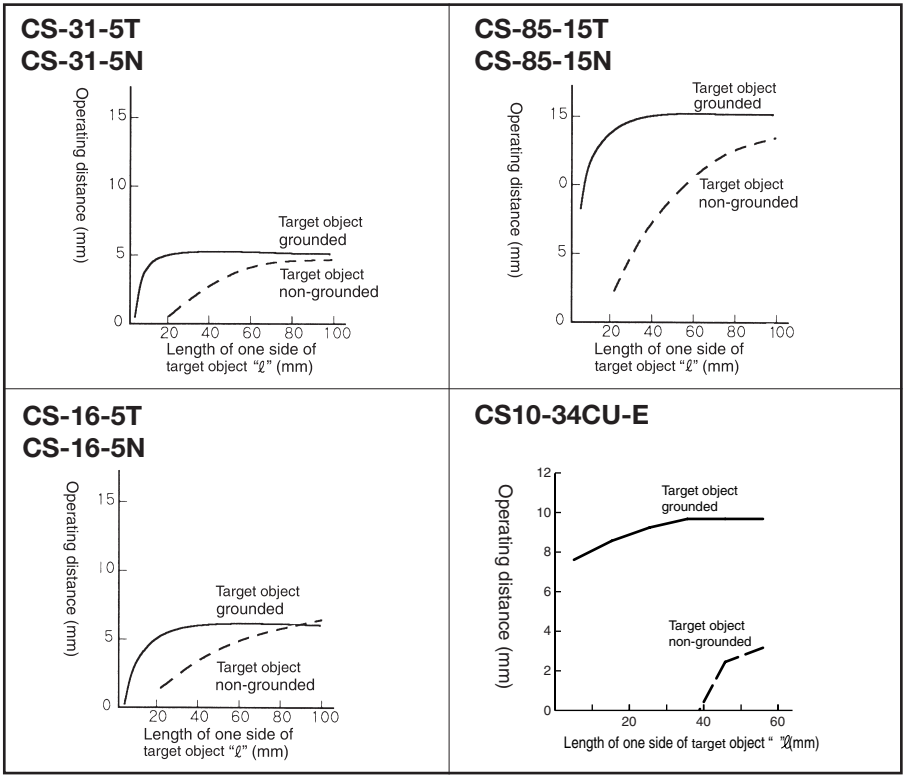

Influence of Amount of Water Droplets on the Detection Plane

The following diagram shows measurements of changes in operating distance when water droplets adhere to the detection plane of a capacitive proximity sensor.

When 0.2 ml of water droplets (2 to 3 droplets) adhere to the detection plane, the operating distance increases by approximately 20%. When water droplets exceed the surface tension limit and start to flow out of the detection plane, the operating distance increases by 300% or more (except CS10-34CU-E).

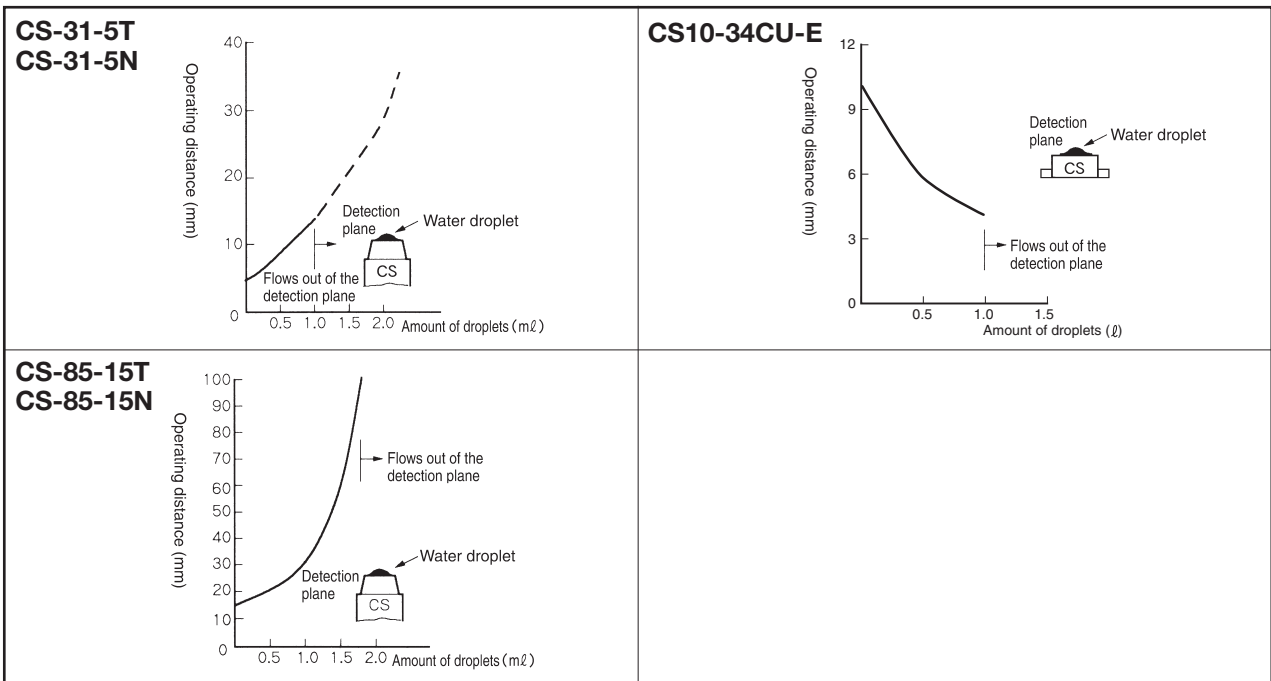

## Conductor Characteristics

A capacitive proximity sensor is capable of detecting a thin conductor (copper, steel, iron, aluminum and other conductors). The figures below show measurements of the operating distance in relation to conductor's diameter. The characteristics assume that the conductor is grounded (or has an infinite length).

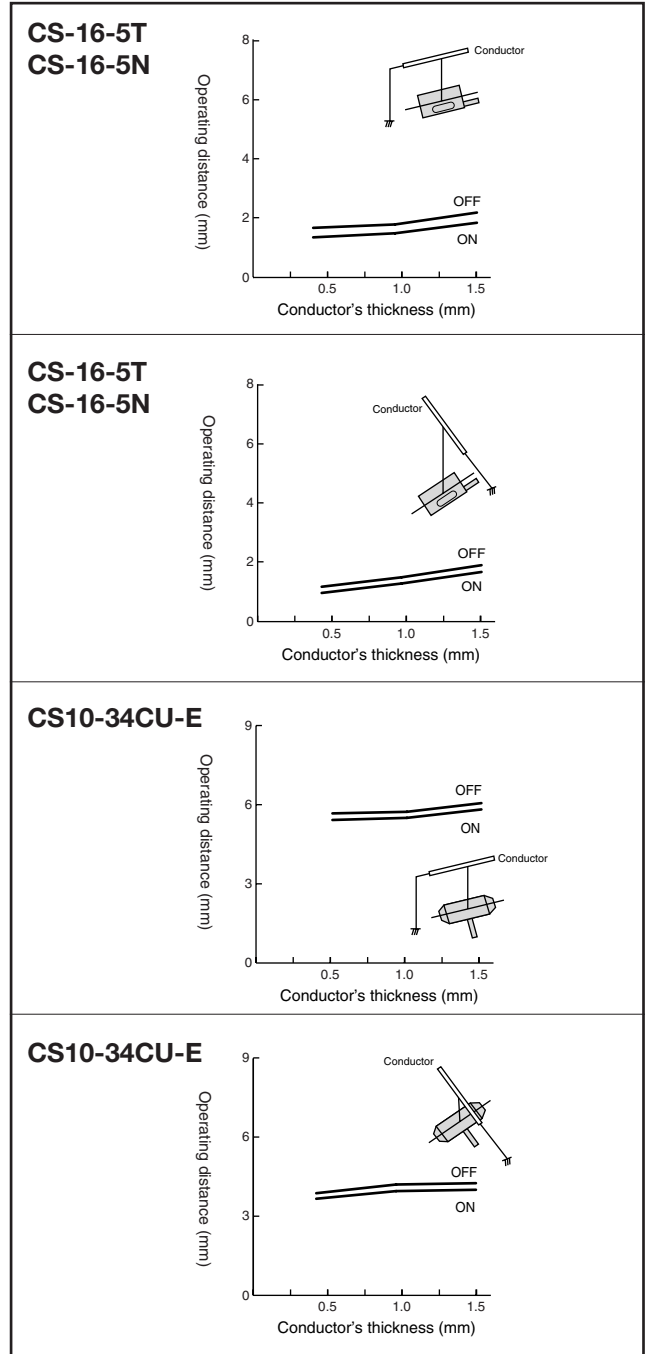
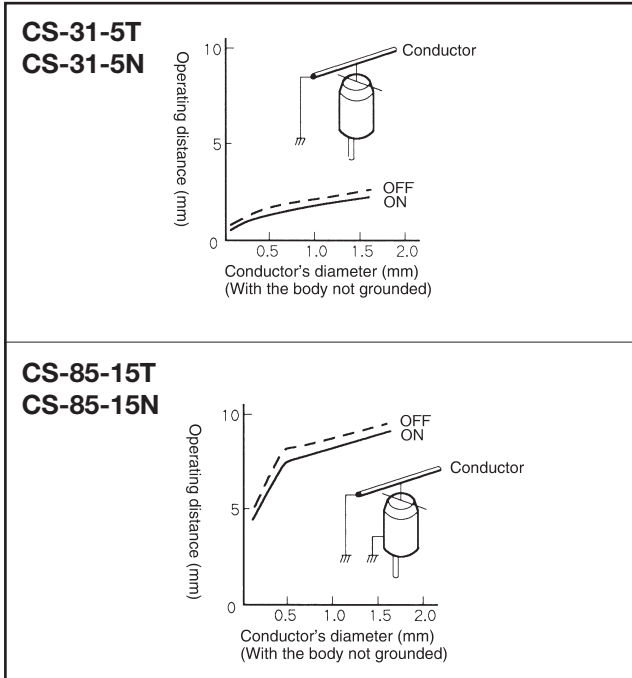

APS-GMC

APS-GMD

APS-GM

APS-GK

APS-30/31

APS-CK

APS-S/M

APS-F/U

APS-10~15

APS-CU

CS