

# 1. TROUBLESHOOTING

## 1-1. Causes of troubles

The following causes may be considered for defective operations to drive the PC.

- (1) Problems to supply power to the system including the PC
  - The power is not supplied.
  - The power source voltage is low.
  - The power source is intermittently cut off.
  - A large noise is given to the power source.
- (2) Damage to the equipment by accident or erroneous operation
  - Application of a higher voltage to the power source (by lightening, etc.)
  - Short circuit on the load
  - Damage to the power equipment (valve, motor, for example) because of mechanical defects
  - Damage to the detector because of mechanical defects
- (3) Incomplete control circuit
  - No matching of the control circuit timing (PC programming, for example) with the mechanical timing
  - Generation of unexpected conditions on the control circuit
- (4) Deterioration and wearing of equipment
  - Defective contact (limit switch, relay, electromagnetic switch, for example) because of mechanical defects
  - Voltage dropping of the memory backup battery in the PC
  - Deterioration of the PC caused by high-voltage noise
- (5) Changes made on the program by noise or erroneous operation
  - Changing of the program by mistake as a result of the monitoring operation
  - Plugging or withdrawing of the module made while the power source is on
  - Changing of the program memory by a large noise

## 1-2. Places to check in case of trouble

To check trouble on the control system using a PC(s), use the I/O display or monitoring features of the PC to define whether the trouble occurred on input/output before the PC operation, in the PC, or after the PC operation. This is the quickest way to provide any countermeasure to the cause of the trouble.

### ● What to check

- (1) Displays on the CPU module or programmer (power source display, CPU abnormality display, RUN display, error display, and BATT display)
- (2) RUN output on the base
- (3) Power source voltage
- (4) Fuse
- (5) I/O module operation display
- (6) Operation monitoring by the programmer
- (7) Program checking by the programmer
- (8) Voltage checking of I/O terminals

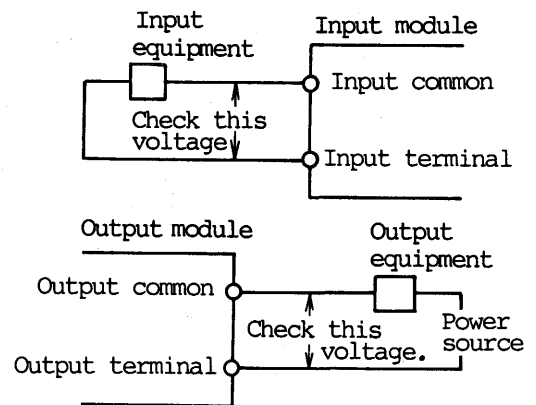

### ● Materials necessary for checking

- (1) Operation chart, wiring diagram, and program (circuit diagram)
- (2) Programmer (A-21P or C-50P)
- (3) Technical manual or operation manual for the PC
- (4) Tester

### ● Points to check

- (1) Investigation of the troubling condition
  - Find out if the operation is partially or completely stopped.
  - Find out if the trouble occurs without fail or sometimes.
- (2) Find out if the CPU is running or not should the operation completely stop (RUN display and output).
- (3) Check input/output if the problem of partial operation constantly continues.
- (4) Check the timing of the program and machine, the condition of the power source, or noises should the problem occur only sometimes.