

HOW MANY OTHER COMPANIES OFFER A MONEY-BACK GUARANTEE ON SOFTWARE?

Simplified packages make your selection fast and easy

(PC-DSOFT5 is our newest *DirectSOFT* revision, with a host of advanced features that make it easier to program your PLC. It supports full-featured 32-bit Windows-certified programming for all six *DirectLOGIC* PLC families simultaneously, including all DL05s, DL06s, DL105s, DL205 CPUs, DL305 CPUs, DL405 CPUs, and all of their Koyo cousins. The software supports an incredible array of on-line/off-line programming and documentation features, as well as our ALL NEW *IBox* instructions.

Packages include:

- PC-DS100 (FREE): Our all new *DirectSOFT* 100 programming pack. Programs up to 100 words in any *DirectLOGIC* CPU
- PC-DSOFT5 is the full programming package for all *DirectLOGIC* PLCs with no programming limitations at lowest price ever \$395.00
- PC-R50-U upgrade to Version 5 with complete DL CPU support regardless of what package you are upgrading \$249.00

Technicians like it when you use our programming and documentation tools

A well-documented program can save thousands of dollars in downtime when something breaks, but not all packages make it easy to document the program. Use our grid-based documentation editor to quickly and intuitively create rung comments, 16-character element nicknames, 6 x 18-character element descriptions, and 16-character wiring labels.

Program over Ethernet

Our Windows programming package has had several years of improvements, one

of which is Ethernet support. You can program one or multiple *DirectLOGIC* PLCs from one location over an Ethernet network. Just insert an Ethernet card in your PC and an ECOM module in supported DL05, DL06, DL205 and DL405 systems to monitor and program at warp speed! For even greater flexibility and improved performance, we now offer our ECOM100 modules with auto-sensing capabilities from 10 to 100 Mbps. An Ethernet setup wizard leads you through the steps to make the connection to your PLCs. Another great feature at no extra charge!

Features

- New *IBoxes* with packetized fill-in-the-blank-style instructions make writing your program faster and easier (certain CPUs required)
- New Tabbed views optimize your viewing area so you see more of what you need to see
- New customizable tool bars give you the flexibility to put what you need where you want it.
- Dockable windows give you the ability to relocate views, auto-hide views and even tear them away and place them outside of the *DirectSOFT*5 workspace for full ladder viewing optimization
- Learn many new features and software shortcuts with the new "Tip of the Day" in *DirectSOFT*5
- Edit programs as fast as you can move a mouse or use "hot keys" (even faster)
- Write your program with nicknames instead of data points
- View your program three different ways (RLI, Stage View, Mnemonics). Select the appropriate Tab or view them all on the same screen

- Spreadsheet-style documentation editor makes it super easy to create and edit your program documentation on the fly
- I/O cross-reference and element usage windows keep track of addresses used
- Print Preview to check print formatting
- Print in COLOR.
- Open a Data View to examine an incredible status chart of information you select. (You can even choose the symbols for ON/OFF conditions.)
- PID setup is a snap. Fill-in-the-blanks for alarms, mode, ramp/soak, process variable, setpoint, gain rate, etc.
- PID loop tune and trending screens are a standard feature
- Modem support is a snap since it uses the standard Windows telephony (TAPI) interface to choose modem configuration.
- Our drum timers are the easiest to create and edit in the industry.
- Programming support for all *DirectLOGIC* CPUs
- ASCII in/out and MODBUS instructions for DL06 and D2-260 CPUs
- Support for DL205 local I/O expansion system in D2-250-1 and D2-260 CPUs
- Support for LCD instructions in the DL06 CPU
- Project backup feature and preferences with auto-backup settings for "file freshen" frequency.
- Import/export program (mnemonics and rung comments) allows for archiving a program in a single file (txt or CSV) that does not need to be in the form of a *DirectSOFT*5 file(s) format.
- Export to *C-MORE* operator interface CSV import format (nickname, type, PLC address) to use the same tags in our PLC program and operator interface configuration.



Now BETTER THAN EVER ... *DIRECTSOFT5*

DirectSOFT5 makes relay ladder logic easier and faster than ever

DirectSOFT programming has never been easier! We have taken the guess work out of everyday programming with the new *IBox* instructions. If you need to setup an Analog card ... fill-in-the blanks; If you need to perform a math function on a value ... type in your expression; Select a new preset for your High Speed Counter (CTRIO); Even send an e-mail with your ECOM100 Ethernet communications module! Take a minute to view the new *IBox* Instruction Help index to see detailed specifications of each of the 66 new instructions, review which CPUs support the new instructions or just get familiar with what they can do for you. We still offer the same great documentation editors with *DirectSOFT5*. Pop up the grid-based documentation editor and start documenting your heart out. Other features include:

- Point and click or function key editing to suit anyone's programming style
- NEW! Customizable Tool Bars for EVERY menu command
- NEW! Desktop Themes to allow you to customize your window and tool bar look & feel.
- NEW! All toolbars can be docked to any border or even floated outside of the *DirectSOFT* window for maximum ladder viewing.
- Write your program with nicknames instead of data points.
- I/O cross reference and element usage windows keep track of addresses used.
- NEW! Set up the new D0-DCM for the DL05 & DL06 right from the menu. PLC > Setup > D0-DCM allows you to configure each of the two serial ports, no ladder code required.

Stage programming keeps the sequence in order

RLL^{PLUS} Stage programming can help break a control problem into smaller pieces and provide such benefits as:

- Stages divide the ladder program into sections that correspond to the states in a flowchart of your process
- Stages help make large programs more manageable by giving them some structure
- Your stage program can have more than one "thread" of execution. For example, you can have an alarm reporting mini-stage program (or recipe handler, data acquisition, etc.) running in parallel with the main logic. This makes stage programming very powerful, because most of the control functions in a system are very asynchronous

We know this software will make you smile. We offer a guarantee to prove it!

Yes, we're confident that our software can stand up to the test, but you should be the judge. That's why we offer a 30-day money-back guarantee. Ever wonder why most of the other guys don't do this?

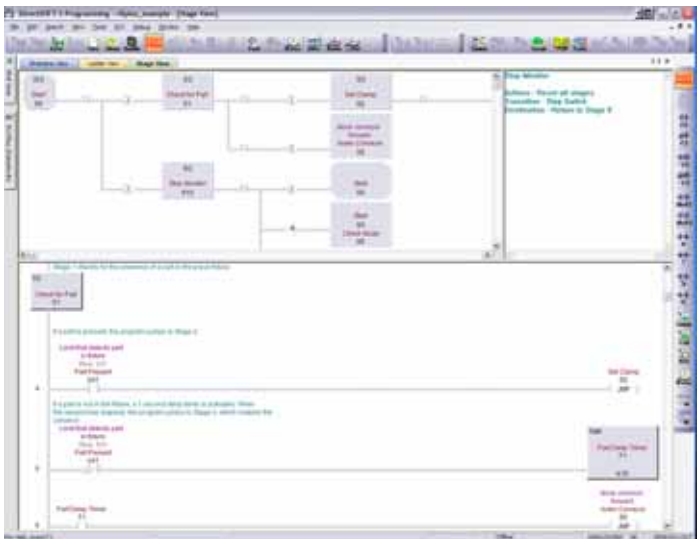
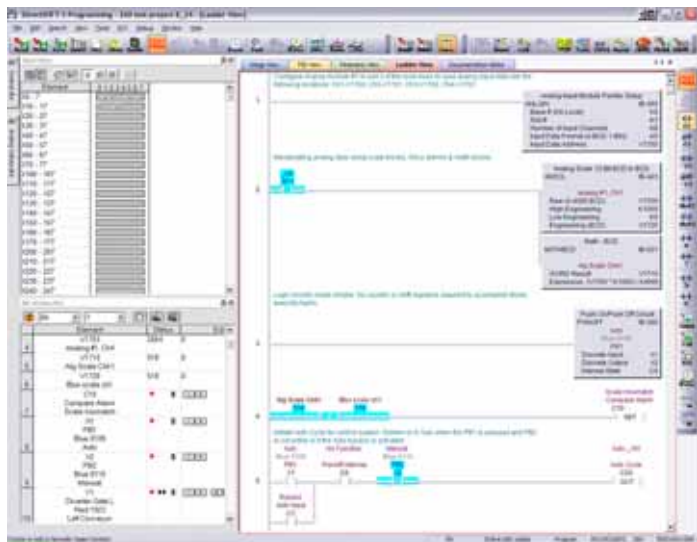
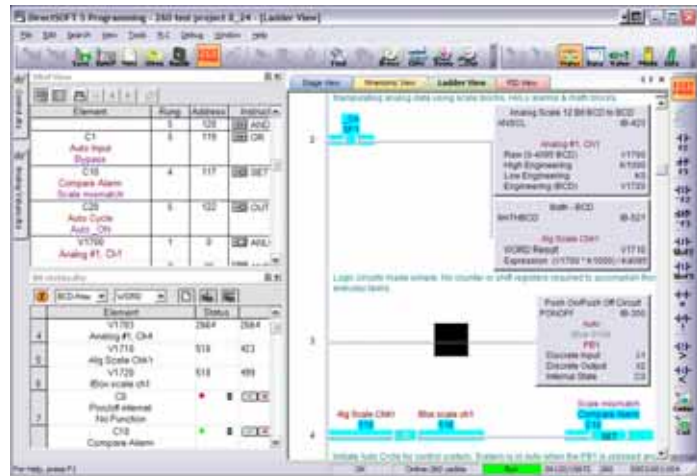

DIRECTSOFT5 PACKAGES

Programming software

PC-DSOFT5 \$395.00
 PC-DS100 Free

Overview

DirectSOFT5 Programming Software single-user licenses have been designed to make PLC programming and machine monitoring easier than ever before. The 32-bit Windows-based package provides simple menu and icon choices that operate similarly to those found in most standard Windows packages. With **DirectSOFT5** you can have the power of Windows on the factory floor.

For more information on **DirectSOFT5** and to download our Free version, please visit our Web site at:

www.automationdirect.com.

Which package is right for you?

The programming software packages share the same general features, but there are a couple of key differences:

PC-DSOFT5 programs all six CPU families (DL05, DL06, DL105, DL205, DL305 and DL405).

PC-DS100 is a free full feature software package that allows a maximum of 100 words for programming, editing, and downloading. Larger programs can be created and saved but NOT reopened or downloaded without upgrading to the full version.

Please note, you can upgrade any older version of DirectSOFT, regardless of the CPU support, and obtain a full programming package with total CPU support, w/ PC-R50-U.

Upgrade the PC-PGM-305, PC-PGM-205, PC-PGM-105 or PC-PGM-BRICK packages to PC-DSOFT5 to support all other product families.

Number of users

The packages listed above are really "single-station" packages. That is, you can legally install them on only one computer. However, if there is only one person who primarily uses the computer (*over 80% of the time*), then you can install the software on a laptop, home office, or any other single backup computer.

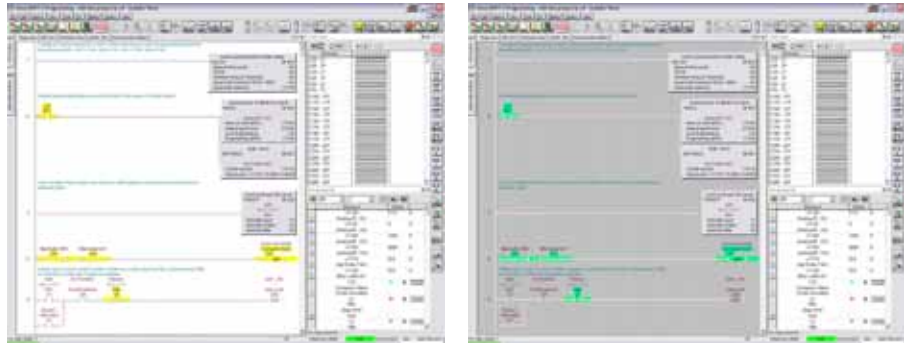

Flexible configuration allows you to customize the look and feel of the software to suit your needs and desires.

Laptop/portable computers and off-site usage

Many of you may be using laptop computers for field service work. This is perfectly acceptable as long as it adheres to the guidelines described previously.

Can I ship a copy to my customer?

No, except for a single backup copy, you cannot make, install, or distribute any additional copies. You can transfer the original copy (original CD, any applicable upgrades, and any documentation) by taking advantage of our Web registration and ownership transfer site.

Of course, this means you cannot legally keep a copy once you have transferred the original.

Maintenance releases

You can receive maintenance releases at no charge by downloading them from our Web site. These often include some minor feature enhancements along with software corrections.

Software upgrades

PC-RXX-U \$249.00

Any release that contains major feature enhancements will be subject to the normal upgrade charge in effect at that time. The **DirectSOFT5** upgrade part number is PC-RXX-U, where XX is the latest release number.

Note: This upgrade will update any packages that are already installed on your system to a full programming package with all CPU support.

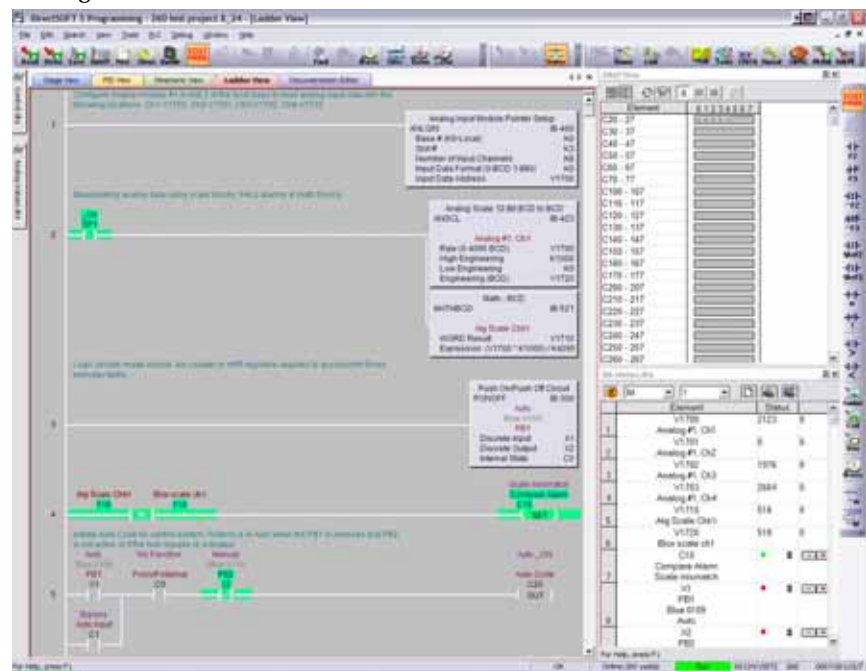

DIRECTSOFT5 FEATURES

Program editing features

- *NEW* - "Tip of the Day" gives you programming guidance, information on short cuts and tips for taking advantage of new features
- Full-screen Point and Click Editing with the mouse and icons
- Edit Tool Box contains icons and hot key equivalents for all elements
- Browsers help you find proper addresses, contacts, coils, and box instructions.
- Neat Windows 2000/XP (Home or Pro) features (fully customizable and tear-off toolbars, Tool Tips, long file names, common file browsers)
- Project Information data with each project including creation and save dates, links, PLC type, project description and version, and company/department/programmer.
- On-screen Cross Reference in a tabbed view that automatically tracks program elements as you browse your ladder view.
- On-screen Element Usage in groups of 8, 10, or 16 points per line
- Predefined aliases for common items, such as timer and counter current values.
- Enter your program with nicknames and assign them to addresses later
- Access V-memory (Data Registers) with fill-in-the-blank Memory Editor
- Easily cut and paste single rungs or groups of rungs.
- Cut and paste rungs (with documentation) between programs
- Search for program elements by name, address, rung number, or instruction type
- Search for constants

Documentation features

- Import/export program mnemonics and rung comments to a single text file that does not have to be in *DirectSOFT* format
- Export (nickname, type, PLC address) to *C-MORE* in CSV format
- Grid-based documentation editor for easy access
- 16-character nicknames for addresses make troubleshooting and programming easier
- 16-character wiring information allows you to tie PLC addresses to panel wiring numbers
- 6-line x 18-character address description provides more detailed information about the program element
- Rung comments can be up to 20 lines of 69 characters each

- Cut, copy, and paste documentation between program elements
- Free-form program title page can be selected at time of printing
- Import/Export feature for all documentation

Printing features

- Print any available view, including ladders, charts, and mnemonics
- Print multiple columns
- Use zoom to enlarge or reduce print size
- Preview the printouts before you send them to the printer
- Create custom printouts by selecting exact items to include for each view
- Print program documentation, including nicknames, descriptions, rung comments, etc.
- Print program Cross Reference or Element Usage Table
- Print PLC V-memory or Data Register contents

Display and viewing features

- View program ladders
- View program mnemonics
- Stage view available for programs created with RLL^{PLUS} instruction
- Choose rung number or addresses for ladder view
- View multiple programs at the same time
- *NEW* - Tabbed views allow you to easily switch between views and optimize your viewing area
- Viewing multiple screens at once is still available (just like *DirectSOFT4*)
- Use split screen to view different sections of the same program
- Use zoom to enlarge or reduce the screen area for better viewing
- *NEW* - Customizable desktop themes, display colors for editing, unsaved changes, documentation, etc.

System setup features

- Set up PID loops with easy-to-use dialog boxes
- Set PLC communication parameters through PC ports, modems, or Ethernet
- *NEW* - Setup D0-DCM menu is available for the DL05 and DL06 data communications module
- Change PLC mode of operation
- Clear PLC memory by type or all
- Select or change retentive memory ranges

- Read PLC I/O configuration
- Change I/O configuration (if allowed by the PLC)
- View PLC firmware revisions
- Configure DV-1000

Online operation features

- Online help system with supported CPU instruction list
- DSLaunch as a central manager for all projects, links, and applications
- Automatically build and store communication links to the PLC, even using modems or Ethernet
- Visible indication of PLC communication link status
- Status mode provides visible power flow condition for program elements, current values for timers and counters, and current values for V-memory or Data Register locations. Even status for Drum steps, outputs, event and/or time transitions, etc.
- Custom configure Data View windows to monitor various elements
- Display nicknames in Data View
- Save and store Data View windows by name
- Choose data format for Data View Window display (BCD, binary, Hexadecimal, etc.)
- Choose status symbol (switch, text, etc.) for discrete points in Data View windows
- Change PLC values from Data View windows
- View multiple PLCs simultaneously

Maintenance and debugging

- Automatic error checking during program entry
- Program syntax check
- Monitor PLC scan time
- Perform PLC I/O diagnostics
- View PLC errors and/or user error messages
- Project user back-up and new auto back-up facilities

DIRECTSOFT5 PROGRAMMING FOR PLCs

Programming versions

Now, with *DirectSOFT5* Programming Software, selecting which software package you need is a snap! You can select the fully loaded package at its newly reduced price, or you may choose the FREE package. It has all of the same programming functions as the full package. However, it will only download a program up to 100 words long.

The fully-loaded version (PC-DSOFT5) will program all of our *DirectLOGIC* PLCs, some GE Series One Plus PLCs, and TI305/405 SIMATIC PLCs. Refer to the chart below to verify compatibility.

The FREE *DirectSOFT5* package (PC-DS100) was designed to provide a more streamlined choice. You can see from the table below that the FREE version has the same support, same great features, but will only allow you to open or download a program up to 100 words long.

Also, you cannot open an offline project larger than 100 words. You can create a project as large as you want, you can save it to disk, but you cannot reopen or download it to a PLC without unlocking the full version (PC-DSOFT5) by purchasing a key.

PLC compatibility

If you're using our *DirectLOGIC* products, then compatibility is not an issue. All NEW *DirectSOFT5* packages support all *DirectLOGIC* CPUs. Our software also supports many compatible products that were offered by previous vendors of the Koyo-designed PLCs. If you're buying the software to program a compatible CPU, check the following table to make sure your CPU is supported. (Sorry, but if your CPU is not shown, then it is not supported.)

Family	CPU	<i>DirectSOFT5</i> (full version) PC-DSOFT5	<i>DirectSOFT5</i> (free version) PC-DS100*	<i>I-Box</i> Instructions (Rel. 5.0 or later)
DL05	All	✓	✓	✓ CPU v5.10 or Later
DL06	All	✓	✓	✓ CPU v2.10 or Later
DL105	All	✓	✓	
DL205	DL-230	✓	✓	
	D2-240	✓	✓	
	D2-250	✓	✓	
	D2-250-1	✓	✓	✓ CPU v4.60 or Later
	D2-260	✓	✓	✓ CPU v2.40 or Later
DL305	D3-330**, D3-330P**	✓	✓	
	D3-340	✓	✓	
	D3-350	✓	✓	
DL405	D4-430	✓	✓	
	D4-440	✓	✓	
	D4-450	✓	✓	✓ CPU v3.30 or Later
GE® Series 1 PLUS	IC610CPU105**	✓	✓	
	IC610CPU106**	✓	✓	
TI305™/ SIMATIC® TI305™	325-07**, PPX:325-07**	✓	✓	
	330-37**, PPX:330-37**	✓	✓	
	325S-07** (or 325 with Stage Kit)	✓	✓	
	330S-37**, PPX:330S-37**	✓	✓	
	335-37, PPX:335-37	✓	✓	
TI405™/ SIMATIC® TI405™	425-CPU, PPX:425-CPU	✓	✓	
	PPX:430-CPU	✓	✓	
	435-CPU, PPX:435-CPU	✓	✓	

* PC-DS100 is only available by download from our Website. This FREE, full-featured software package will download a program limited to 100 words.

** Requires Data Communications Unit (D3-232-DCU).

DIRECTSOFT5 PROGRAMMING FOR PLCs

PC system compatibility

Following are the recommended system requirements for running *DirectSOFT5* on a PC:

- 1 GHz CPU
- CD-ROM for loading software
- Windows 2000/XP (Home and Pro)
No DOS, OS/2, Macintosh, LINUX or UNIX versions, or 16-bit versions available
- 512 MB RAM and 20 MB free hard disk space
- At least one unused serial communications port, USB port with USB-to-serial adapter and/or 10-Base-T or 10/100-Base-T Ethernet network card
- Color SVGA monitor (1024 x 768)

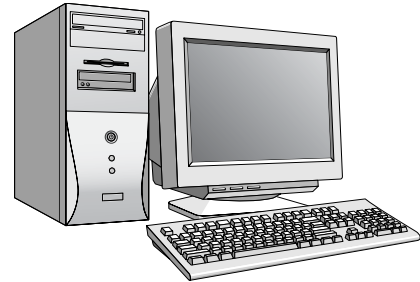

NOTES:

Laptops: *DirectSOFT5* is perfectly suitable for use with laptop computers as long as they meet the requirements shown above. Most laptops can be ordered with a serial port as an option, which will allow a direct connection to our *DirectLOGIC* PLCs. If your laptop has a USB port, consider using our USB to serial adapter, USB-RS232. If your laptop has an Ethernet port and you are considering a DL05, DL06, DL205 or DL405 PLC, consider using the H*-ECOM or ECOM100 Ethernet Communications Module to connect your PC to the PLC (The D2-230 does not support the ECOM).

Monitors: Any size monitor will work, however, larger, higher resolution, monitors enhance the features of *DirectSOFT5*.

Connecting to *DirectLOGIC* PLCs

DL05 CPUs

Two built-in ports
Max. baud = 38.4 K

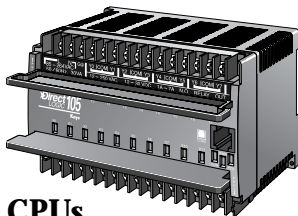
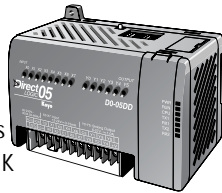

DL105 CPUs

One built-in port
Fixed baud = 9.6 K

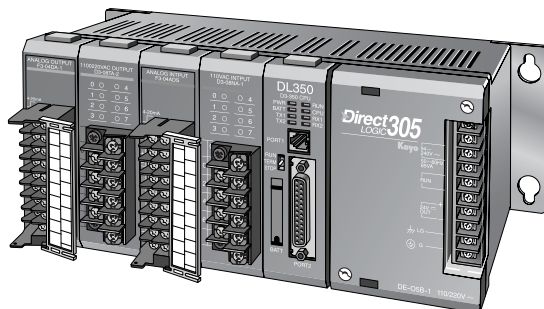

DL305 CPUs

D3-330 requires D3-232-DCU; max. baud = 19.2 K
Two built-in ports D3-340/350; max. baud = 38.4 K

DL06 CPUs

Two built-in ports
Max. baud = 38.4 K

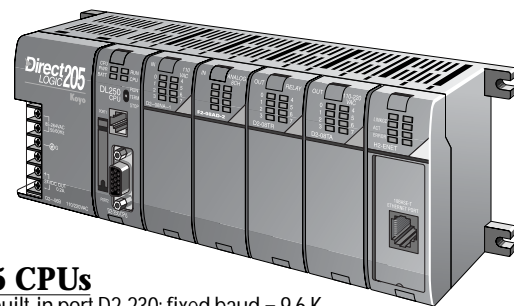

DL205 CPUs

One built-in port D2-230; fixed baud = 9.6 K
Two built-in ports D2-240; max. baud = 19.2 K
Two built-in ports D2-250(-1)/260 max. baud = 38.4 K

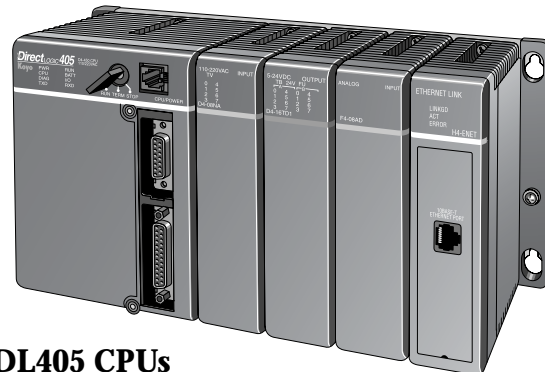

DL405 CPUs

Two built-in ports D4-430/440; max. baud = 19.2 K
Four built-in ports D4-450; max. baud = 38.4 K

Or use an ECOM module in the DL05, DL06, DL205 (except D2-230) or DL405 local base to program over a high-speed Ethernet link.

PLC PROGRAMMING CABLES

Since CPUs provide many different communication port possibilities, it is helpful to know exactly which communications cable is required. Use the table below to choose the proper cable:

Family	CPU (or other device)	Port	Cable
DirectLOGIC DL05	All versions	Port 1	D2-DSCBL
		Port 2	D2-DSCBL
DirectLOGIC DL06	All versions	Port 1	D2-DSCBL
		Port 2	D2-DSCBL-1
DirectLOGIC DL105	F1-130 (all versions)	Only one	D2-DSCBL
DirectLOGIC DL205	D2-230	Only one	D2-DSCBL
	D2-240	Top port	D2-DSCBL
		Bottom port	D2-DSCBL
	D2-250(-1)	Top port	D2-DSCBL
		Bottom port	D2-DSCBL-1
	D2-260	Top port	D2-DSCBL
		Bottom port	D2-DSCBL-1
D2-DCM (module)	Only one	D3-DSCBL-2	
H2-ECOM /-F (modules)	Only one	**	
DirectLOGIC DL305	D3-330/D3-330P	Requires DCU*	D3-DSCBL-2
	D3-340	Top port	D3-DSCBL-1
		Bottom port	D3-DSCBL-1
	D3-350	Top port	D2-DSCBL
		Bottom port	D3-DSCBL-2
D3-DCM (module)	Only one	D3-DSCBL-2	
DirectLOGIC DL405	D4-430/D4-440	Top port (15-pin)	D4-DSCBL
		Bottom port (25-pin)	D3-DSCBL-2
	D4-450	Phone jack	D2-DSCBL
		Top port (15-pin)	D4-DSCBL
		Bottom port (25-pin)	D3-DSCBL-2
	D4-DCM (module)	Only one	D3-DSCBL-2
	H4-ECOM (module)	Only one	**
Slice I/O (module)	Only one	D4-DSCBL	
GE® Series 1	IC610CPU105/106	Requires DCU*	D3-DSCBL-2
T1305™/SIMATIC® T1305™	325-07, PPX:325-07	Requires DCU*	D3-DSCBL-2
	330-37, PPX:330-37	Requires DCU*	D3-DSCBL-2
	325S-07 (or 325 with stage kit)	Requires DCU*	D3-DSCBL-2
	330S-37, PPX:330S-37	Requires DCU*	D3-DSCBL-2
	335-37, PPX:335-37	Phone jack	D3-DSCBL-1
		If DCU is used*	D3-DSCBL-2
T1405™/SIMATIC® T1405™	425-CPU, PPX:425-CPU	If DCU is used*	D4-DSCBL
	N/A, PPX:430-CPU	Top port (15-pin)	D4-DSCBL
		Bottom port (25-pin)	D3-DSCBL-2
	435-CPU, PPX:435-CPU	Top port (15-pin)	D4-DSCBL
		Bottom port (25-pin)	D3-DSCBL-2
	Smart slice	Only one	D4-DSCBL

* Requires RS232 Data Communications Unit (D3-232-DCU).

**Requires standard Ethernet twisted pair cable (HX-ECOM) or standard fiber optic cable (HX-ECOM-F).

PLC PROGRAMMING CABLES

Pin labeling conforms to IBM DTE and DCE standards

D2-DSCBL \$30.00

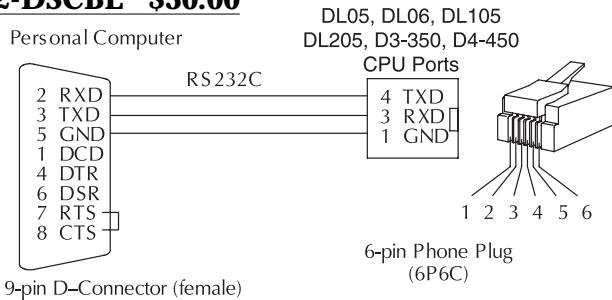

D2-DSCBL-1 \$30.00

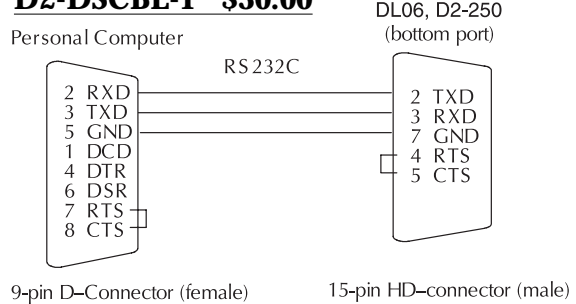

D3-DSCBL-1 \$30.00

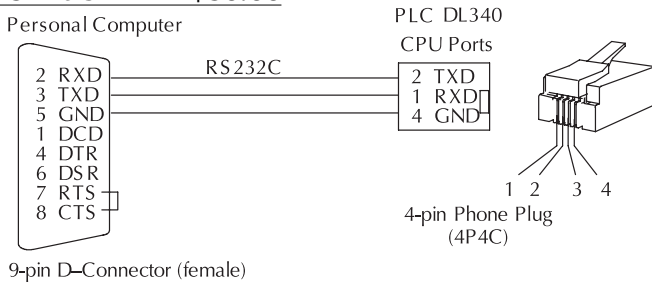

D3-DSCBL-2 \$30.00

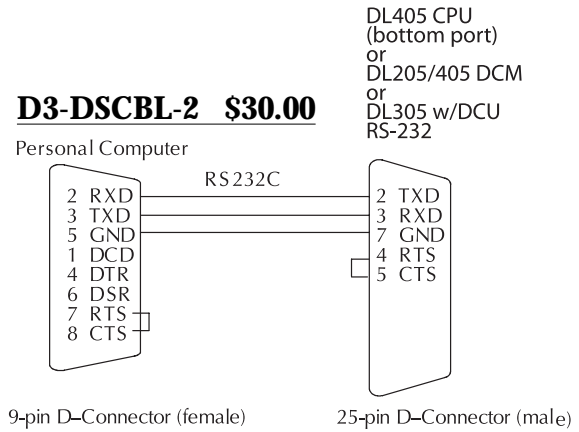

D4-DSCBL \$30.00

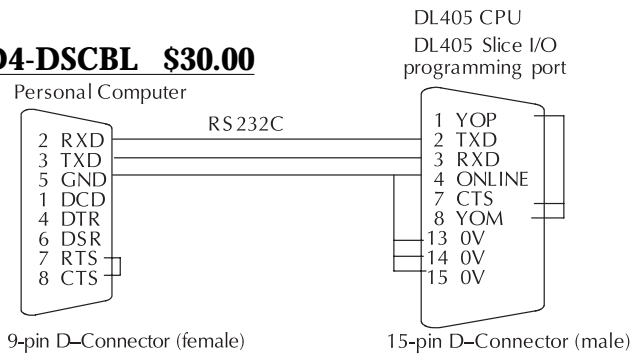

Straight-through Patch Cable (Ethernet)

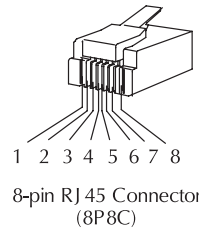
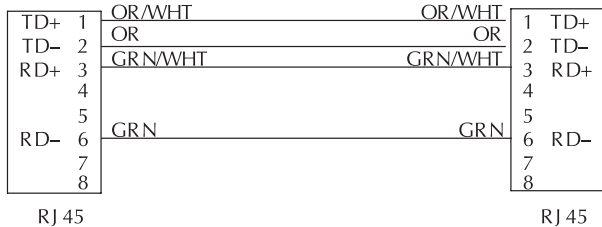

Crossover Cable (Ethernet)

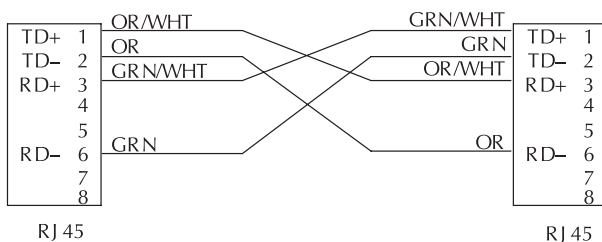

All Ethernet and ECOM patch cables should be Category 5, UTP Cable. The diagram illustrates the appropriate wire position in the RJ 45 connector.

DIRECTSOFT5 FUNCTIONS

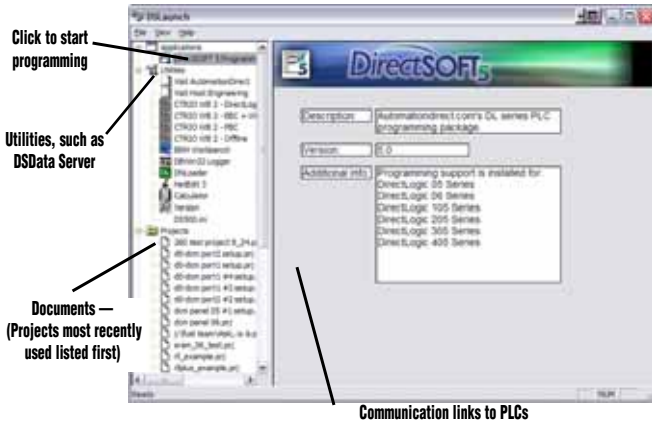

The Launch Window

The Launch Window is a centralized location to view not only all of your *DirectSOFT5* applications and projects, but also any additional applications such as HMI software, DSData Server, utilities, etc. This window is also used to create and manage PLC programs and the communications between your PC and the PLC.

Point and click editing

Once you have started a new project, there are a few different ways to start building your program. The Ladder Palette, which is attached to the right border by default, can be resized and repositioned anywhere on your desktop. This contains most of the instructions you will need for access to the browser. Simply click on the icon or use the Hot Key associated with that icon. Some instructions have to be accessed through one of the Browser icons. The Browsers contain all of the necessary information from various boxes, coils, and contacts. You can now customize the Ladder Palette tool bar to fit your programming style and needs.

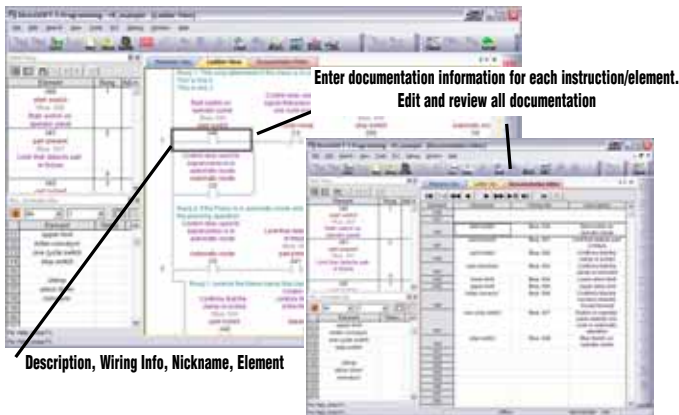
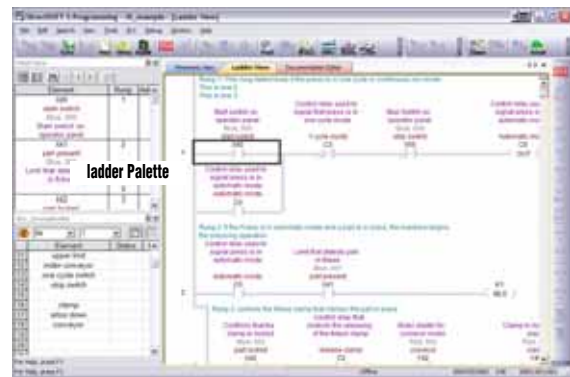

Documentation

Documentation is the text associated with the components and structure of your program. It helps to clarify the representation of elements by assigning four different fields: Description, Wiring Info, Nickname, and Element.

On-screen views

DirectSOFT5 defaults to a new Tab view to give you the most optimized viewing area. You still have the option to view multiple windows in the original "MDI" format by simply hitting the Restore button in the upper right of the active tabbed window, or go to Windows menu and select one of the tile or cascade options. You can have multiple windows open to view such things as all of the addresses used in the program, a mnemonic view of the program instructions, and all of the instructions used.

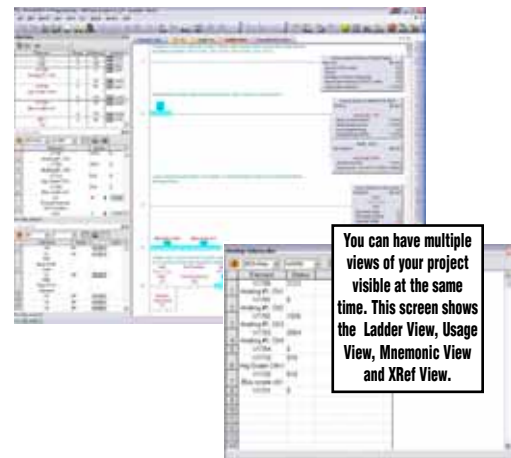

DIRECTSOFT5 FUNCTIONS

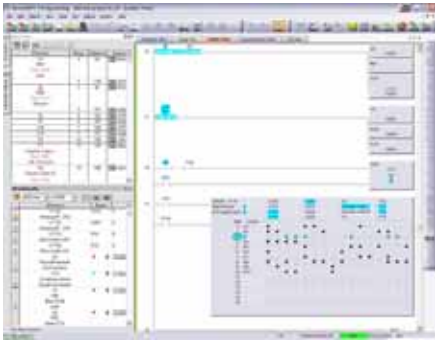

Support for drum instructions

If your PLC supports Drum instructions, you will like this feature of the programming software. Simply fill in the top of the drum with outputs and configure each step with an event and/or time-based element. Then click on the output boxes to choose the proper output states for each step and you are finished.

PID view

DirectSOFT5 offers an excellent PID feature. The loop and trending screens are very easy to configure. This feature has all of the views, trending, and tuning that you need to easily and successfully set up your PID loop.

NEW! I-Box Instructions

The most notable new feature in *DirectSOFT5* is the addition of the parameterized *I-Box* instructions. These fill-in-the-blank instructions were designed to make your programming experience quicker & easier than ever before. Within these *I-Boxes* you will find some complicated & some simple, every day ladder code tasks made easy and fast. You will find 6 new categories to select from, including Memory, Discrete Helper, Analog Helpers, Math, Communications & Counter I/O, with more than 65 new instructions to choose from. Here are a few examples of what you can expect from the new *I-Box* instructions in *DirectSOFT5* ...

MOVED - moves a double word to two consecutive memory locations

OFFDTMR - Off Delay Timer will delay the "turning off" of the Output parameter by the specified Off Delay Time

PONPOFF - Push On/Push OFF Circuit toggles an output state whenever its input power flow transitions from off to on

ANLGCMB - Analog Input/Output Combo Module Pointer Setup generates the logic to configure the pointer method for one analog input/output combo module on the first PLC scan following a Program to Run transition.

MATHBCD - Math - BCD Format lets you enter complex mathematical expressions like you would in Visual Basic, Excel, or C++

SUMBCD - Sum BCD Numbers sums up a list of contiguous 4-digit WORD BCD numbers into an 8-digit DWORD BCD result.

ECEMAIL - ECOM100 Send EMail, on a leading edge transition, will behave as an EMail client and send an SMTP request to your SMTP Server to send the EMail message to the EMail addresses in the To: field

(* requires an Hx-ECOM100 100MBit communications module, capable of accessing an SMTP server, in the PLC)

CTREDRL - CTRIO Edit Preset Table Entry and Reload, on a leading edge transition to this IBox, will perform this dual operation to a CTRIO Output resource in one CTRIO command.

(* requires a Hx-CTRIO counter I/O module in the PLC)

